



SAM Electronics Corporation

## SL100 Series

Universal Low-power Inverter User Manual



# 目 录

<b>1 Product Introduction .....</b>	<b>1</b>
1.1 Description of inverter model .....	1
1.2 Model of inveter series .....	1
1.3 Product appearance and name of components .....	2
1.4 Product technical indicators and specifications .....	3
<b>2 Inverter Installation .....</b>	<b>6</b>
2.1 Environmental requirements .....	6
2.2 Installation dimension of inverters .....	8
<b>3 Inverter Wiring .....</b>	<b>9</b>
3.1 Wiring precautions .....	9
3.2 Wiring of peripheral elements .....	10
3.3 Basic wiring .....	13
3.4 Wiring of main loop terminal .....	14
3.5 Wiring of control loop terminal .....	15
<b>4 Operating Panel.....</b>	<b>17</b>
4.1 Panel instructions.....	17
4.2 Panel operating method.....	18
4.3 List of status monitoring parameters.....	20
4.4 Simple operation of the inverter.....	20
4.4.1 Initial setting.....	20
4.4.2 Simple running.....	21

<b>5 Function Parameter Table .....</b>	<b>22</b>
<b>6 Detailed Description of functions .....</b>	<b>34</b>
6.1 Basic operating parameter group .....	34
6.2 Basic control parameter groups .....	41
6.3 Motor parameter group .....	47
6.4 Digital input and analog parameter group .....	49
6.5 Digital output and swing frequency operation parameter group .....	54
6.6 Multi-speed section and PLC operating parameter group .....	59
6.7 Communication setting parameter group .....	62
6.8 PID parameter group .....	65
<b>7 Fault Diagnosis And Countermeasures .....</b>	<b>67</b>
7.1 Protection function and countermeasures .....	67
7.2 Fault record query .....	69
7.3 Fault reset .....	69
<b>Appendix I : MODBUS Protocol Specification.....</b>	<b>70</b>
<b>Appendix II : Brake Resistor Selection .....</b>	<b>76</b>

## Precautions

SL100 series universal low-power inverters are applicable to general industrial single-phase and three-phase AC asynchronous motors. If this inverter is used for equipment which is failed and may cause personal injury (e.g. nuclear control system, aviation system, safety equipment and instruments), please take care and consult with the manufacturer; if it is used for dangerous equipment, that equipment should be provided with safety protecting measures to prevent accident expansion in the case of inverter failure. The inverter is produced under strict quality assurance system. However, in order to protect your personal safety and equipment and property safety, before using this inverter, please read this chapter carefully and conduct transportation, installation, operation, commissioning and inspection according to relevant requirements.



### 1. Precautions of unpacking inspection

When unpacking, please confirm if

- (1) There is any damage during transportation and any components are damaged or dropped.
- (2) The model and specifications stated on the inverter nameplate is consistent with your order. If there is any omission or damage, please contact your supplier promptly.

#### Nameplate of the inverter

On the left side of the inverter body, there is a nameplate marked with the model and rated parameters of the inverter.

TYPE	SL100-2S0004BQ
SOURCE	1PH 220V 50/60Hz
OUTPUT	1.1KVA 3.0A
SERIAL No.	XXXXXXXXXX
  	

Inverter model  
 Rated input voltage phase, voltage and frequency  
 Rated output capacity and current  
 Product serial number

QR code, certification mark

## II Precautions

### Label on the outer box

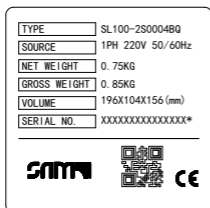

Inverter model  
Rated input voltage phase, voltage and frequency  
Net weight  
Gross weight  
Carton size  
Product serial number

QR code, certification mark

### Weight and dimension

Model		Net weight (KG)	Gross weight (KG)	Outer box dimension(mm)
	SL100-2S0004(B)Q	0.85	0.95	196X104X156
SL100-4T0007(B)Q	SL100-2S0007(B)Q			
SL100-4T0015(B)Q	SL100-2S0015(B)Q			
SL100-4T0022(B)Q	SL100-2S0022(B)Q	1.2	1.35	211X124X161
SL100-4T0040(B)Q	SL100-2S0030(B)Q			
SL100-4T0055(B)Q	SL100-2S0040(B)Q	1.9	2.15	266X166X181
SL100-4T0075(B)Q				

We have strict quality assurance system for the products in terms of manufacturing, packing and transportation. In case of any careless omission, please contact us or local agent immediately. We will address the problem at first time.

## 2. Safety precautions

In this manual, the wordings of “Danger” and “Caution” are defined as below.



**Danger:** Serious damage to the equipment or personal injuries may be caused if operating without following requirements.



**Caution:** Moderate injuries or minor injuries of personnel and material loss may be caused if operating without following

## 2.1 Installation

1. The inverter shall not be installed on combustibles.
2. The frequency inverter shall not be installed at places with direct sunlight.
3. The frequency inverter of this series shall not be installed in the environment of explosive gases, for fear of the danger of explosion.
4. No foreign matter is allowed to be dropped into the frequency inverter, for fear of causing fires or injury.
5. During installation, the frequency inverter shall be installed at the place able to bear its weight; otherwise, it may fall down or damage properties.



The inverter shall not be dismantled or modified without authorization.requirements.

## 2.2 Wiring

1. Wire diameter shall be selected according to applicable electric code, and wiring shall be done by qualified technicians.
2. Wiring shall not be started unless the power supply of the inverter is completely disconnected.
3. The grounding terminal of the inverter must be reliably grounded; otherwise, there can be a danger of electric shock.
4. Before wiring, make sure the power supply has been disconnected for over 10minutes; otherwise, there may be a danger of electric shock.
5. The electronic elements in the inverter is quite sensitive to static electricity, hence no foreign articles shall be placed into the inverter or contact the main board.



No alternating current power supply is allowed to be connected onto the U, V, and W of the inverter.

## 2.3 Maintenance



Wiring, inspection and other maintenance work shall not be done until the power supply is disconnected for 10 minutes.

### 3. Precautions of use

In this manual, the wordings of “Tip” and “Attention” are defined as below:



Tip: To give some useful information.



Attention: To indicate any precautions during operation.

1. The inverter shall be installed in the place with good ventilation.
2. The motor’s temperature can be a little higher than that of industrial frequency power during operation of the inverter, which is abnormal.
3. With long-term operation at low speed, the operation life of motor can be affected due to the poorer heat dissipation effect. In this case, special frequency converter shall be selected or the motor’s load shall be decreased.
4. When the altitude is over 1000m, the inverter shall be derated. Increase of altitude for every 1500 m shall be ground for derating by 10%.
5. If the operating environment is beyond the allowed conditions of the inverter, please consult the manufacturer.



The inverter’s output terminal shall not be connected to any filter capacitor or other RC absorption equipment.

### 4. Scrapping precautions

Following attentions shall be paid when the inverter and its components are abandoned:

**Explosion of the electrolytic capacitor:** electrolytic capacitor in the frequency converter may cause explosion while burning.

**Waste gas from plastic burning:** harmful and toxic gas may be produced during combustion of plastic and rubber products of the converter.

**Disposal:** please dispose of inverters as industrial wastes.

## Chapter1 Product Introduction

### 1.1 Description of inverter model

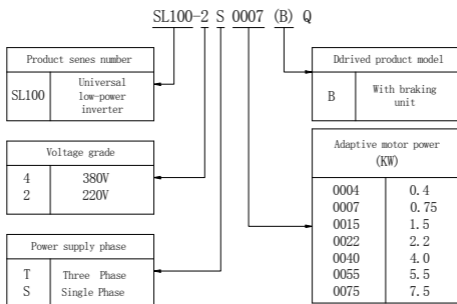

### 1.2 Model of inverter series

Inverter model	Rated capacity (KVA)	Rated output current(A)	Adaptive motor power (KW)
SL100-2S0004(B)Q	1.1	3.0	0.4
SL100-2S0007(B)Q	1.9	5.0	0.75
SL100-2S0015(B)Q	2.9	7.5	1.5
SL100-2S0022(B)Q	3.8	10.0	2.2
SL100-2S0030(B)Q	5.3	14.0	3.0
SL100-2S0040(B)Q	6.3	16.5	4.0
SL100-4T0007(B)Q	1.6	2.5	0.75
SL100-4T0015(B)Q	3.0	4.5	1.5
SL100-4T0022(B)Q	3.6	5.5	2.2
SL100-4T0040(B)Q	6.3	9.5	4.0
SL100-4T0055(B)Q	8.6	13	5.5
SL100-4T0075(B)Q	11.2	17	7.5

### 1.3 Product appearance and name of components

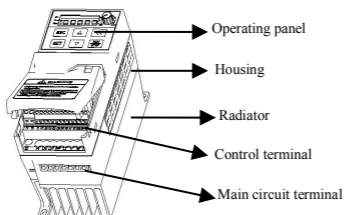

Name of Category I Inverters

Applicable models: SL100-2S0004(B)Q

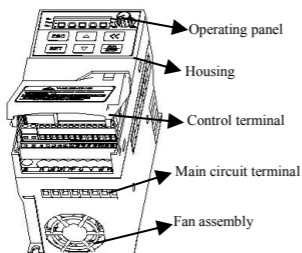

Name of Category II Inverters

Applicable models:

SL100-2S0007(B)Q~SL100-2S0015(B)Q

SL100-4T0007(B)Q~SL100-4T0015(B)Q

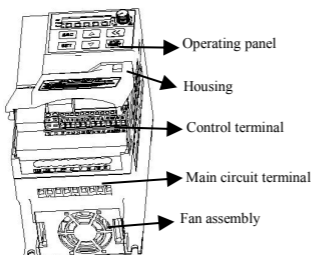

Name of Category III Inverters

Applicable models:

SL100-2S0022(B)Q~SL100-2S0040(B)Q

SL100-4T0022(B)Q~SL100-4T0075(B)Q

## 1.4 Product technical indicators and specifications

Input	Rated voltage, frequency	Three phase (4T# series) 380V50/60Hz	Single phase (2S# series) 220V50/60Hz
	Allowed variation range of voltage	380 ~ 415V ± 10%	220V ± 10%
Output	Voltage	0 ~ input voltage	0 ~ input voltage
	Frequency	0.00~400Hz	
	Overload capacity	110%--long term; 150%--1 minute; 180%--2 second	
Control mode		V/F	
Control Characteristics	Frequency set resolution	Analog terminal input	0.1% of the maximum output frequency
		Digital setting	0.01Hz
	Frequency precision	Analog input	Within 0.1% of the maximum output frequency
		Digital input	Within 0.1% of the set output frequency
	V/F curve (Voltage frequency characteristics)		Reference frequency can be set within 5~400Hz, and multi-node V/F curve can be randomly set.

## 4 Product Introduction

	Torque increase	Manual setting: 0.0~20.0% of rated output.	
	Automatic current limiting and voltage limiting	Automatically detect motor's stator current and voltage and control it within allowable range according to special algorithm, regardless of any running process like acceleration, deceleration or static running.	
	Under voltage limiting during running	Especially for users of low-grid voltage and frequently fluctuating grid voltage. Even within the voltage range lower than allowable value, the system can maintain longest running time according to special algorithm and residual capacity distribution strategy.	
Typical functions	Multispeed control	7-section programmable multispeed control and 5 kinds of running modes available for selection.	
	Optional built-in PID controller	Internal integrated optimized PID controller, allowing for simple closed-loop control.	
	RS485 communication and linkage control	MODBUS protocol.	
	Frequency setting	Analog input	DC voltage 0-10V, and DC current 0-20mA (optional)
		Digital input	Operating panel setting, potentiometer setting, RS485 port setting, UP/DW terminal control, and multiple combined setting with analog input.
	Output signal	Relay and OC output	One channel OC output and One channel relay output (TA, TC), with up to 16 kinds of optional meanings.
		Analog output	One channel 0-10V voltage signal, and upper and lower limit can be set.
	Automatic voltage regulation running	Three kinds of voltage regulation modes including dynamic, static and none are available for selection according to different requirements, so as to achieve most stable running effect.	
	Setting of acceleration and deceleration time	0.1~600.0Sec continues setting.	
	Running function	Setting of upper and lower limiting frequency, REV running limiting, RS485 communication, and control of progress increase and decrease of frequency, etc.	

<b>Display</b>	Display of operation panel	Running status	Output frequency, output current, output voltage, motor revolution, set frequency, module temperature, analog input and output and so on.
		Alarm content	The nearest 4 times of fault records, five items of running parameter records at the time of latest fault trip including, the output frequency, output current, output voltage, DC voltage and modular temperature.
<b>Protection/ alarm function</b>		Over current, overvoltage, under voltage, overheat, short circuit, internal memory fault, etc	
<b>Environment</b>		Surrounding temperature	-10°C to +45°C (no freezing)
		Surrounding humidity	90% below (no frosting)
		Surrounding environment	Indoor (Free of direct sunlight, corrosion, flammable gas, oil mist and dusts)
		Altitude	0~1000m, the load is derated by 10% for each kilometer increase.
		Protecting grade	IP20
		Cooling mode	Forced air cooling (Model 2S0004(B)Q is natural air cooling without fan).
<b>Installation mode</b>		wall-mounted (Model 2S0004(B)Q must be mounted vertically on the wall)	
<b>Vibration</b>		<6m/s <sup>2</sup>	

## Chapter2 Inverter Installation

### 2.1 Environmental requirements

This series of inverters are wall-mounted products and shall be vertically installed to facilitate air circulation and heat dissipation. Following attentions shall be paid for selecting installation environments.



1. The ambient temperature shall be within  $-10^{\circ}\text{C}$ — $45^{\circ}\text{C}$ . High-temperature and humid places shall be avoided, and the inverter shall be better placed in a place with humidity lower than 90% and without frosting.
2. Direct sunshine should be avoided.
3. The inverter should be away from flammable, explosive and corrosive gas and liquid.
4. The environment should be free of dust, floating fibers and metal particles.
5. The installation surface should be solid without ventilation.
6. The inverter should be away from electromagnetic interference sources.
7. If there is too much dust in the environment, please close the cooling hole.(As show in figure 2-1-A)

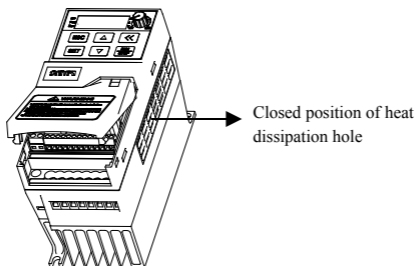

Figure 2-1-A

**If you have any special installation requirements, please contact us in advance.**

See Figure 2-1-B for installation spacing and distance requirement for single inverter. Enough space should be left around the inverter. For installation of multiple inverters, baffle plate should be applied between inverters to ensure good heat dissipation, as shown in Figure 2-1-C.

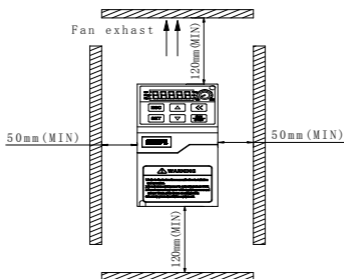

Figure 2-1-B Installation Spacing Distance

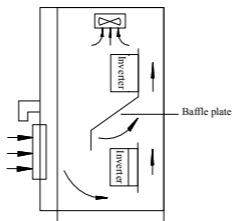
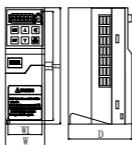
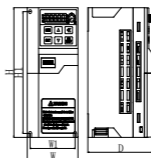

Figure 2-1-C Installation of Multiple Inverters

## 2.2 Installation dimension of inverters



Category I and II inverters  
 SL100-2S0004(B)Q-SL100-2S0015(B)Q  
 SL100-4T0007(B)Q-SL100-4T0015(B)Q



Category III inverters  
 SL100-2S0022(B)Q  
 SL100-4T0022(B)Q-SL100-4T0075(B)Q

The specific installation dimensions of SL100 series inverters are shown in following table:

Inverter model (three-phase 380V)	Inverter model (single-phase 220V)	W1	W	H1	H	D	Screw specification
	SL100-2S0004(B)Q	59	68	139	148	110	M4
SL100-4T0007(B)Q	SL100-2S0007(B)Q						
SL100-4T0015(B)Q	SL100-2S0015(B)Q						
SL100-4T0022(B)Q	SL100-2S0022(B)Q	78	88	155	165	113	M4
SL100-4T0040(B)Q	SL100-2S0030(B)Q						
SL100-4T0055(B)Q	SL100-2S0040(B)Q	99	109	199	209	135	M4
SL100-4T0075(B)Q							

## Chapter3 Inverter Wiring

### 3.1 Wiring precautions

- (1) Make sure intermediate circuit breaker is connected between the frequency inverter and power supply to avoid expanded accident when the frequency inverter is faulty.
- (2) In order to reduce electromagnetic interference, please connect surge sorber on the coil of electromagnetic contactor, relay and etc. in the surrounding circuit of the frequency inverter.
- (3) Please use shielded wire of above  $0.3\text{mm}^2$  for the wiring of such analog signals as frequency setting terminal AI and instrument loop (AO), etc. The shielding layer shall be connected on the grounding terminal E of the frequency inverter with wiring length less than 30m.
- (4) The stranded wire or shielded wire of above  $0.75\text{mm}^2$  shall be selected for the wiring of input and output loop (X1-X4) of relay; and the shielded layer shall be connected to the common port CM of control terminals, with wiring length less than 50 m.
- (5) The control wire shall be separated from the power line of major loop; it shall be at a distance of above 10cm for parallel wiring and vertical for cross wiring.
- (6) The connecting wire between the inverter and the motor shall be less than 30m; and when it is longer than 30m, the carrier frequency of the inverter shall be appropriately reduced.
- (7) All leading wires shall be fully fastened with terminals to ensure good contact.
- (8) The pressurization of all the leading wires shall be in compliance with the voltage class of the frequency inverter.



Absorption capacitor or other RC absorbers shall not be installed at U, V and W output end of the frequency inverter, as shown in figure 3-1.

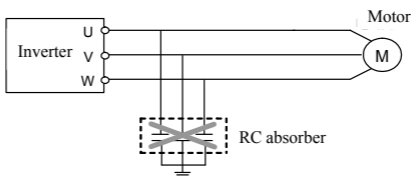

Figure 3-1 Forbidding connecting a RC absorber at the output terminal

### 3.2 Wiring of peripheral elements

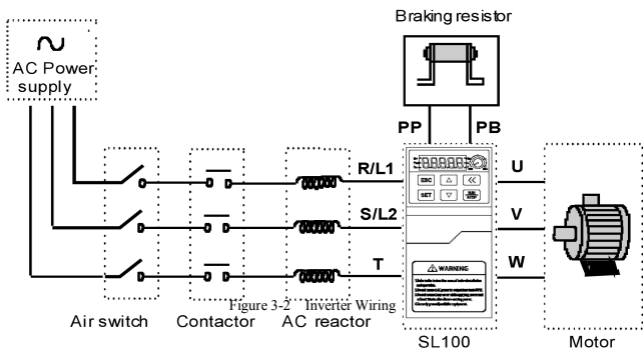

Figure 3-2 Inverter Wiring

#### ◆ Power supply

The inverter shall be provided with power in accordance with specification of input power supply designated by this operating manual.

#### ◆ Air switch

- 1) When the frequency inverter is maintained or not in use for a long time;
- 2) the air switch will separate the frequency inverter from the power supply;
- 3) When the input side of the frequency inverter has failures like short circuit, the air switch can provide protection.

◆ **Contactor**

It can conveniently control power-supply and power disconnection of the inverter, and the power-on and power-off of the motor.

◆ **AC reactor**

- 1) To promote power factor;
- 2) To reduce harmonic input of the inverter against the grid;
- 3) Weaken influenced caused by unbalanced voltage of three-phase power supply.

◆ **Brake resistance**

When the motor is at the dynamic braking status, it can avoid producing over high pumping voltage in the DC loop.

Recommended specifications are shown in following table:

Inverter model	Adaptive motor (KW)	Wire specification (main loop) (mm <sup>2</sup> )	Air circuit breaker (A)	Electromagnetic contactor (A)
SL100-2S0004(B)Q	0.4	1.5	16	6
SL100-2S0007(B)Q	0.75	2.5	20	12
SL100-2S0015(B)Q	1.5	2.5	32	18
SL100-2S0022(B)Q	2.2	4.0	32	18
SL100-2S0030(B)Q	3.0	6.0	40	32
SL100-2S0040(B)Q	4.0	6.0	40	32
SL100-4T0007(B)Q	0.75	1.0	10	6
SL100-4T0015(B)Q	1.5	1.5	16	12
SL100-4T0022(B)Q	2.2	2.5	16	12
SL100-4T0040(B)Q	4.0	4.0	32	18
SL100-4T0055(B)Q	5.5	6	32	22
SL100-4T0075(B)Q	7.5	6	40	32

Main loop terminal

Inverter model	Screw specification	Tightening torque (N*m)	Recommended wire ear model
SL100-2S0004(B)Q	M3.5	0.7~0.9	PTV1.25-9
SL100-2S0007(B)Q	M3.5	0.7~0.9	PTV2-9
SL100-2S0015(B)Q	M3.5	0.7~0.9	PTV5.5-13
SL100-2S0022(B)Q	M3.5	0.7~0.9	PTV5.5-13
SL100-2S0030(B)Q	M3.5	0.7~0.9	PTV5.5-13
SL100-2S0040(B)Q	M3.5	0.7~0.9	PTV1.25-9
SL100-4T0007(B)Q	M3.5	0.7~0.9	PTV1.25-9
SL100-4T0015(B)Q	M3.5	0.7~0.9	PTV2-9
SL100-4T0022(B)Q	M3.5	0.7~0.9	PTV5.5-13
SL100-4T0040(B)Q	M4	1.2~1.5	RNY5.5-4S
SL100-4T0055(B)Q	M4	1.2~1.5	RNY5.5-4S

## 12 Inverter Wiring

SL100-4T0075(B)Q								
General control terminal		Screw specification	Tightening torque (N*m)		Recommended wire ear model			
Control board/extension card terminal		M2	0.1~0.2		E0.5-6			
Control board/extension card terminal		M3	0.3~0.4		E0.75-6			
Wire ear model		W (mm)	F (mm)	L (mm)	H (mm)	d1 (mm)	D (mm)	T (mm)
PVT/E series	PVT1.25-9	1.9	9	19	10	1.7	4.2	0.8
	PVT2-9	1.9	9	19	10	2.3	4.7	0.8
	PVT5.5-13	2.8	13	26	13	3.4	6.5	1
	E0.5-6	1.1	6	12	6	1	2.6	/
	E0.75-6	1.1	6	12.3	6.3	1.2	2.8	/

Wire ear model		d2 (mm)	W (mm)	F (mm)	L (mm)	H (mm)	d1 (mm)	D (mm)	T (mm)
RNY series	RNY 5.5-4S	4.3	7.2	5.9	22.5	13	3.4	6.7	1

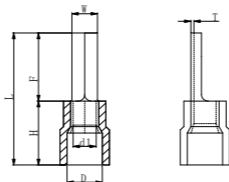

**PVT/E series**

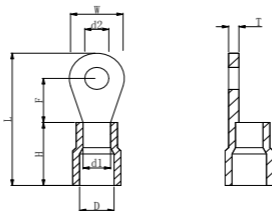

**RNY series**

### 3.3 Basic wiring

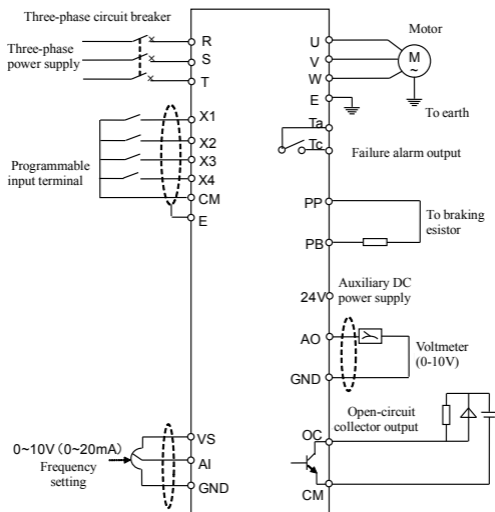

Figure 3-3 Basic Wiring of Inverter

### 3.4 Wiring of main loop terminal

#### Category I main loop terminal

Applicable models:

SL100-2S0004(B)Q-2S0007(B)Q-4T0007(B)Q-4T0015(B)Q

	<b>Symbol</b>	<b>Function</b>
	PP	DC side voltage positive terminal
	PB	Braking resistor can be connected between PP and PB
	R, S/L, T/N	To grid single-phase AC 220V/ three-phase 380V power supply. L: Live wire N: Neutral wire
	U, V, W	To three-phase AC 220V motor.
E	Earthing terminal	

#### Category II main loop terminal

Applicable models:

SL100-2S0022(B)Q-2S0030(B)Q-4T0022(B)Q-4T0040(B)Q

	<b>Symbol</b>	<b>Function</b>
	PP	DC side voltage positive terminal
	PB	Braking resistor can be connected between PP and PB
	R/L, S/N, T	To grid single-phase AC 220V/ three-phase 380V power supply. L: Live wire N: Neutral wire
	U, V, W	To three-phase AC 220V/380V motor
E	Earthing terminal	



**Reverse connection of live wire and neutral wire is prohibited.**

### Category III main loop terminal

Applicable models:

SL100-2S0040(B)Q-SL100-4T0055(B)Q-4T0075(B)Q

	<b>Symbol</b>	<b>Function</b>
	PP	DC side voltage positive terminal
	PB	Braking resistor can be connected between PP and PB
	R/L、S/N、T	To grid three-phase AC 380V power supply
	U、V、W	To three-phase AC 380V motor
E	Earthing terminal	

### 3.5 Wiring of control loop terminal

(1) Diagram of control loop terminal

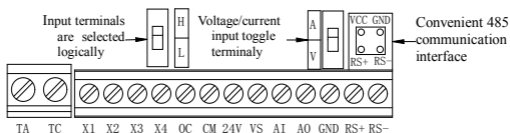

(2) Function description of control loop terminal

Type	Terminal symbol	Terminal function	Remarks
Power supply	VS	Externally providing +10V (0~10mA) power supply	
	24V	External providing +24V (0~50mA) power supply (CM terminal is the power grand).	
Analog input	AI	Voltage signal input terminal (when the toggle switch is set to V)	The input range: 0~10V
		Current signal input terminal (when the toggle switch is set to A)	The input range: 0~20mA
	GND	Analog input signal common terminal (VS power ground)	

## 16 Inverter Wiring

Control terminal	X1	Multifunctional input terminal 1	The function of the multi-function input terminal is set by the parameters [F3.01]~[F3.04], and it is effective when closed; in the logic selection of the input terminal, when the toggle switch is turned to L, the terminal and CM are closed and effective, and when the switch is to H, the terminal is connected to 24V End closure effective.
	X2	Multifunctional input terminal 2	
	X3	Multifunctional input terminal 3	
	X4	Multifunctional input terminal 4	
Analog output	AO	Programmable voltage signal output terminal (external voltage meter set by [F3.16])	Voltage signal output 0-10V.
OC output	OC	Programmable open-circuit collector output, set by parameter [F4.00]	Maximum load current 50mA and maximum withstanding voltage 24V.
Programmable output	TA/TC	Normally open contact capacity: AC 250V, 1A resistive load ,TA-TC function is set by parameter [F4.01].	
Communication	RS+/RS-	485 communication port	Convenient communication interface uses special cable (optional) to copy/download parameters conveniently through 485 communication.

## Chapter4 Operating Panel

### 4.1 Panel instructions

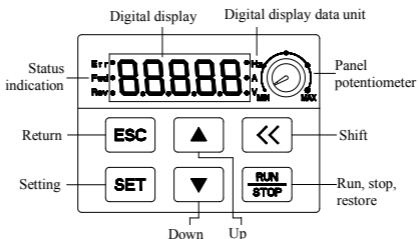





Figure 4-1 Operating Panel Sketch

Keys	Function Description
Digital display	Display the current operating status parameters and setting parameters of the frequency inverter.
A, Hz, V	Display the measurement unit corresponding to the main digital display data.
Fwd	The forward running indicator light indicates that the inverter is running forward and the output terminals U, V, W have output voltage.
Rev	Reverse running indicator light indicates that the inverter is running reversely and output terminals U, V, W have output voltage.
Err	Fault status indicator, indicating that the inverter is in fault status.
▲ ▼	<b>Data modification key.</b> It is used to modify functional code or parameters. At the status monitoring mode, if the frequency command channel is at the digital setting mode ([F0.00]=0), press this key to directly modify the frequency set value.
ESC	<b>Back key.</b> At the normal monitoring mode, press this key to enter the non-normal monitoring mode/monitoring parameter inquiry mode to see the operating status parameters of the inverter. At any other operating status, separately press this key to back to the previous status.
SET	<b>Set key.</b> Confirm the current status or parameter (parameters are stored in the internal memorizer) and enter the next function menu.

	<p><b>RUN/STOP command key.</b> When the command channel selects control panel ([F0.06] =###0), this key is effective. The key is a trigger key. When the inverter is at the stop status, press this key to input stop command to stop running. At the inverter fault status, this key is also used as the fault reset key.</p>
	<p><b>Shift key.</b> When modifying data with any data modification key, press this key to select the data digit to be modified, and the selected digit will flash.</p>
	<p><b>Panel potentiometer.</b> When the inverter's running frequency is set by the potentiometer on the operating meter (F0.00=3), rotate the potentiometer knob counterclockwise to decrease running frequency, and rotate it clockwise to increase running frequency.</p>

## 4.2 Panel operating method

### (1) Status parameter inquiry (example)

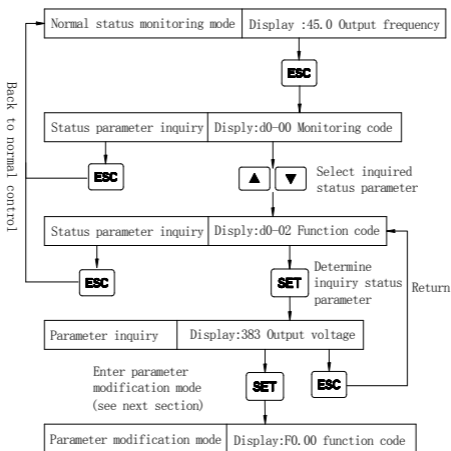



### 4.3 List of status monitoring parameters

Monitoring code	Content	Unit
d-00	Inverter's current output frequency	Hz
d-01	Inverter's current output current (effective value)	A
d-02	Inverter's current output voltage (effective value)	V
d-03	Motor revolution	rpm
d-04	Voltage at the DC terminal in the inverter	V
d-05	Inverter's input AC voltage (effective value)	V
d-06	Module temperature	°C
d-07	Set frequency	Hz
d-08	Analog input AI	V
d-09	Running liner speed	
d-10	Set liner speed	
d-11	Input terminal status	
d-12	Analog output AO	V
d-13~d-19	Reserve	
d-20	First fault record	
d-21	Second fault record	
d-22	Third fault record	
d-23	Forth fault record	
d-24	Output frequency at the time of recent fault	Hz
d-25	Output currenry at the time of recent fault	A
d-26	Output voltage at the time of recent fault	V
d-27	DC voltage at the time of recent fault	V
d-28	Module temperature at the time of recent fault	°C
d-29	Set frequency at the time of recent fault	Hz
d-30	Running status at the time of recent faul	
d-31	Reserve	

## 4.4 Simple operation of the inverter

### 4.4.1 Initial setting

- (1) Channel selection for frequency input ([F0.00])

Inverter's initial setting varies from each other according to different models.

When the parameter is set to 0, the inverter's frequency setting will be set through the panel digit.

- (2) Selection of running command input channel ([F0.06])

The inverter's initial setting varies according to different models. When this parameter is set to [F0.06] =###0, the inverter's start and stop control will be completed through  key on the operating panel.

## 4.4.2 Simple running



It is absolutely forbidden to connect the power cord to the output U, V, W of the frequency inverter.

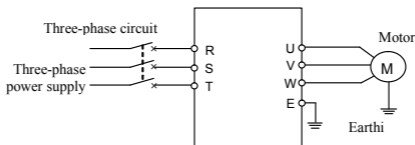





Figure 4-2 Simple Running Wiring Diagram

- ① Connect wires as per Figure 4-2;
- ② Switch on the power supply after confirming that the wires are connected correctly, and the inverter will firstly display “P.oFF” and then “0”.
- ③ Confirm that the frequency setting channel is at the digit setting model ([F0.00] = 0);
- ④ It is required to set parameter [F2.00] and [F2.01] according to the rated nameplate data on the inverter’s dragging motor.
- ⑤ Press  key to start the inverter and the inverter will input 0 frequency, displaying “0.0”.
- ⑥ Press Up of  key to increase set frequency, and the output frequency of the inverter will increase and the motor revolution will also increase.
- ⑦ Check if the motor run normally. In case of any abnormality, stop running the motor immediately and disconnect power supply. Do not run the motor until fault cause is found.
- ⑧ Press Down on the  key to decrease set frequency.
- ⑨ Press  key again to stop running and cut off the power supply.



The default value of the carrier frequency is fixed (2-8 KHz). If the motor is completely empty-load, slight oscillation may occur sometimes in the operation under high carrier frequency. At this time, please reduce the setting value of the carrier frequency. (Parameter [F0.08]).

## Chapter 5 Function Parameter Table

Parameter Type	Function Code	Name	Setting Range and Description	Minimum unit	Default setting	Modification limit
Basic running parameter group	F0.00	Frequency input channel	<b>0:</b> Digital setting <b>1:</b> External analog quantity <b>2:</b> External communication <b>3:</b> Panel potentiometer <b>4:</b> External terminal selection <b>5:</b> Combination setting	1	3	
	F0.01	Frequency digital setting	0.00Hz ~ upper limit frequency	0.01	50.00	
	F0.02	Parameter write protection	<b>0:</b> All parameters can be modified <b>5:</b> Only allow to rewrite F0.01 parameter and this parameter <b>9:</b> Only allow to modify this parameter <b>Other values:</b> all parameters are allowed to be rewritten	1	0	
	F0.03	Upper limit frequency	5.00~400.00	0.01	50.00	
	F0.04	Lower limit frequency	0.00~[F0.03]	0.01	0.00	

Function Parabeter Table 23

	F0.05	Lower limit frequency operation mode	<p><b>0:</b> Output the lower limit frequency [F0.04] when it is lower than the lower limit frequency [F0.04]</p> <p><b>1:</b> Output zero frequency when it is lower than the lower limit frequency [F0.04]</p>	1	0	
	F0.06	Run command channel And mode selection	<p><b>LED units:</b> Run command channel selection</p> <p><b>0:</b> keyboard control <b>1:</b> External terminal control <b>2:</b> Serial communication port</p> <p><b>LED ten digits:</b> Run command mode selection</p> <p><b>0:</b> Two-line mode 1 <b>1:</b> Two-line mode 2 <b>2:</b> Three-line mode 1 <b>3:</b> Three-line mode 2</p> <p><b>Hundreds of LEDs:</b> reserved</p> <p><b>LED thousands:</b> Power-on self-start</p> <p><b>0:</b> Prohibition of self-starting after power-on <b>1:</b> Power-on self-start allowed</p>	1	1000	

24 Function Parameter Table

F0.07	Running direction setting	<b>LED units :</b> Reverse running direction <b>0:</b> invalid <b>1:</b> Inverted direction <b>LED ten bits :</b> Orientation lock <b>0:</b> invalid <b>1:</b> Reverse prevention <b>2:</b> Prevention of forward rotation	1	0000
F0.08	Carrier frequency	2.0~ 8.0k	0.1	5.0
F0.09	Carrier characteristics	<b>LED bits:</b> temperature correlation adjustment <b>0:</b> invalid <b>1:</b> valid <b>LED ten bits:</b> fundamental frequency correlation adjustment <b>0:</b> invalid <b>1:</b> valid <b>LED hundreds:</b> reserved <b>LED thousands:</b> reserved	1	0000
F0.10	Parameter initialization	<b>0:</b> Invalid <b>1:</b> Standard initialization <b>2:</b> Clear fault record <b>3:</b> Full initialization	1	0
F0.11	Reserve			
F0.12	Combination setting selection	0~11	1	0
F0.13	Reserve			
F0.14	acceleration time	0.01 ~ 600.00 Sec	0.01	5.00

Function Parameter Table 25

	F0.15	Deceleration time	0.01 ~ 600.00 Sec	0.01	5.00	
	F0.16	Jog acceleration time	0.01 ~ 600.00 Sec	0.01	5.00	
	F0.17	Jog deceleration time	0.01 ~ 600.00 Sec	0.01	5.00	
	F0.18	Forward jog frequency	0.00~[F0.03]	0.01	5.00	
	F0.19	Reverse jog frequency	0.00~[F0.03]	0.01	5.00	
Basic control parameter group	F1.00	Start pre-excitation voltage	0.0~20.0%	0.1	2.0	
	F1.01	Start pre-excitation time	0.00~10.00	0.01	0.0	
	F1.02	Start frequency	0.00~min (F0.03,100.0)	0.01	1.00	
	F1.03	Start frequency hold time	0.00~10.00	0.01	0.0	
	F1.04	Stop mode	<b>0:</b> Deceleration shutdown <b>1:</b> Free shutdown	1	0	
	F1.05	DC braking frequency at stop	0.0~min (F0.03,100.0)	0.01	5.00	
	F1.06	DC braking voltage at stop	0.0~20.0%	0.1	3.0	
	F1.07	DC braking time at stop	0.00~20.00	0.01	0.00	
	F1.08	Energy consumption braking level	340~400/650~800	1	360/680	
	F1.09	Dynamic braking action selection	<b>0:</b> Action only when decelerating <b>1:</b> Not limited by deceleration	1	0	

26 Function Parameter Table

F1.10	Inhibition of action selection	<b>LED bits:</b> undervoltage suppression <b>0:</b> invalid <b>1:</b> valid <b>LED ten bits:</b> overvoltage suppression <b>0:</b> invalid <b>1:</b> valid <b>LED hundreds:</b> acceleration current limit <b>0:</b> invalid <b>1:</b> valid <b>LED thousands:</b> operating current limit <b>0:</b> invalid <b>1:</b> valid	1	1111	
F1.11	Undervoltage suppression level	160~220/340~420	1	190/380	
F1.12	Overvoltage suppression level	350~400/650~800	1	360/700	
F1.13	Accelerating current limit level	120~220	1	180	
F1.14	Operating current limit level	120~220	1	200	
F1.15	Reserve				
F1.16	Motor overload protection level	10~130%	1	110	
F1.17	Reserve		1		
F1.18	Failure self-recovery times	0~5	1	0	
F1.19	Fault self-recovery time	0.00~600.00	0.01	1.00	

Function Parameter Table 27

Motor parameter group	F2.00	Fundamental frequency	5.00~400.00	0.01	50.00	
	F2.01	Maximum output voltage	25~250V/50~500V	1	220/380	
	F2.02	Torque boost	0.0~20.0%	0.1	3.0	
	F2.03	V/F frequency 1	0.00~[F2.00]	0.01	0.00	
	F2.04	V/F voltage 1	0~[F2.01]	1	0	
	F2.05	V/F frequency 2	0.00~[F2.00]	0.01	0.00	
	F2.06	V/F voltage 2	0~[F2.01]	1	0	
	F2.07	V/F frequency 3	0.00~[F2.00]	0.01	0.00	
	F2.08	V/F voltage 3	0~[F2.01]	1	0	
	F2.09	V/F voltage selection	<b>0:</b> Standard <b>1:</b> Enhanced	1	0	
	F2.10	Zero frequency torque hold	<b>0:</b> invalid <b>1:</b> valid	0	0	
	F2.11	Automatic voltage stabilization	<b>0:</b> Invalid <b>1:</b> Invalid deceleration <b>2:</b> Effective	1	0	
	F2.12	Number of motor pole pairs	1~16	1	2	
	F2.13	Reserve				
	F2.14	Reserve				
	F2.15	Reserve				
	F2.16	UP/DW terminal rate	0.10~10.00	0.01	1.00	
	F2.17	UP/DW frequency power down preservation	<b>0:</b> Do not save <b>1:</b> Power down preservation	1	0	
	F2.18	Reserve				
F2.19	Reserve					

28 Function Parameter Table

Digital input and analog parameter group	F3.00	Input terminal characteristics selection	0000~1111	1	0000	
	F3.01	Multi-function terminal X1	0~21	1	11	
	F3.02	Multi-function terminal X2	0~21	1	0	
	F3.03	Multi-function terminal X3	0~21	1	13	
	F3.04	Multi-function terminal X4	0~21	1	0	
	F3.05 ~ F3.08	Reserve				
	F3.09	AI input lower limit voltage	0.00~[F3.10]	0.01	0.00	
	F3.10	AI input upper limit voltage	[F3.19]~10.00	0.01	10.00	
	F3.11	AI input filter time	0~200	1	10	
	F3.12	Minimum set frequency	0.00~[F3.13]	0.01	0.00	
	F3.13	Maximum set frequency	[F3.12]~[F0.03]	0.01	50.00	
	F3.14	Reserve				
	F3.15	Reserve				
	F3.16	AO output selection	0~2	0	0	
	F3.17	AO output lower limit voltage	0.00~[F3.18]	0.01	0.00	
	F3.18	AO output upper limit voltage	[F3.17]~10.00	0.01	10.00	
	F3.19	Reserve				

Digital output and swing frequency operation parameter group	F4.00	OC output selection	0~10	1	0	
	F4.01	RLY output selection	0~10	1	8	
	F4.02	Output characteristic selection	0000~0011	1	0000	
	F4.03	RLY output delay	0.00~30.00	0.01	0.00	
	F4.04	Reserve				
	F4.05	Reserve				
	F4.06	Reserve				
	F4.07	Frequency reach detection range	0.00~[F0.3]	0.01	5.00	
	F4.08	FDT settings	0.00~20.00	0.01	10.00	
	F4.09	FDT action delay	0.00~20.00	0.01	0.00	
	F4.10	Overload alarm level	20~200%	1	110	
	F4.11	Overload alarm delay	0.00~600.00	0.01	5.00	
	F4.12	Reserve				
	F4.13	Reserve				
	F4.14	Swing frequency operation setting	<b>LED bits:</b> function setting <b>0:</b> Function Invalid <b>1:</b> Function valid <b>LED ten bits:</b> center frequency selection <b>0:</b> set value of swing center frequency <b>1:</b> Given value of frequency channel <b>LED hundreds:</b> reserved <b>LED thousands:</b> reserved	1	0000	
F4.15	Swing frequency center frequency	0.00~[F0.3]	0.01	25.00		

30 Function Parameter Table

	F4.16	Swing frequency amplitude	0.0~50.0%	0.1	20.0	
	F4.17	Reserve				
	F4.18	Swing frequency rise time	0.01~600.00	0.01	1.00	
	F4.19	Swing frequency fall time	0.01~600.00	0.01	1.00	
Multi-stage speed and PLC operating parameter group	F5.00	Multi-speed operation mode	<b>LED bits:</b> multi segment speed action selection <b>0:</b> invalid <b>1:</b> valid <b>2:</b> Condition valid <b>LED ten bits:</b> mode selection <b>0:</b> single cycle <b>1:</b> maintain final value <b>2:</b> maintain set value <b>3:</b> continuous cycle <b>LED hundreds:</b> reserved <b>LED thousands:</b> reserved	1	0000	
	F5.01	Multi-speed frequency 1	0.00Hz ~ upper limit frequency	0.01	35.00	
	F5.02	Multi-speed frequency 2	0.00Hz ~ upper limit frequency	0.01	15.00	
	F5.03	Multi-speed frequency 3	0.00Hz ~ upper limit frequency	0.01	3.00	
	F5.04	Multi-speed frequency 4	0.00Hz ~ upper limit frequency	0.01	20.00	
	F5.05	Multi-speed frequency 5	0.00Hz ~ upper limit frequency	0.01	25.00	
	F5.06	Multi-speed frequency 6	0.00Hz ~ upper limit frequency	0.01	30.00	
	F5.07	Multi-speed frequency 7	0.00Hz ~ upper limit frequency	0.01	35.00	
	F5.08	Phase 1 running time	0.0S~6000.0s	0.1	0.0	

Function Parameter Table 31

	F5.09	Phase 2 running time	0.0S~6000.0s	0.1	0.0	
	F5.10	Phase 3 running time	0.0S~6000.0s	0.1	0.0	
	F5.11	Phase 4 running time	0.0S~6000.0s	0.1	0.0	
	F5.12	Phase 5 running time	0.0S~6000.0s	0.1	0.0	
	F5.13	Phase 6 running time	0.0S~6000.0s	0.1	0.0	
	F5.14	Stage 7 running time	0.0S~6000.0s	0.1	0.0	
	F5.15	PLC multi-speed running direction 1	0000~1111H	1	0000	
	F5.16	PLC multi-speed running direction 2	0000~0111H	1	0000	
	F5.17	PLC running timed shutdown	0~9999(min)	1	0	
	F5.18	Reserve				
	F5.19	Reserve				
Communication setting parameter group	F6.00	Communication settings	<b>LED bits:</b> baud rate selection <b>0:</b> reserved <b>1:</b> 1200bps <b>2:</b> 2400bps <b>3:</b> 4800bps <b>4:</b> 9600bps <b>5:</b> 19200bps <b>LED hundreds:</b> data format <b>0:</b> No verification <b>1:</b> Parity check <b>2:</b> Odd check <b>LED hundreds:</b> reserved <b>LED thousands:</b> reserved	0000	0004	
	F6.01	Local address	0~127	1	1	

32 Function Parameter Table

F6.02	Response delay	0~1000	1ms	2	
F6.03	Linkage function	0000~0011	1	0000	
F6.04	Overtime checkout time	0.1~20.0	0.1s	2.0	
F6.05	Communication disconnection action selection	<b>0:</b> Shutdown <b>1:</b> Run as last state	1	0	
F6.06	Communication setting factor	0.100~10.000	0.001	1.000	
F6.07	Reserve				
F6.08	Permission password	0~60000	1	0	
F6.09	Program Version	1100~1199	1	1100	
F6.10	Monitoring parameter selection	0~20	1	0	
F6.11	Linear speed coefficient setting	0.001~60.000	0.001	1.000	
F6.12	Reserve				
F6.13	Reserve				
F6.14	Reserve		1	0	
F6.15	Reserve				
F6.16	Operation restriction password	0~60000	1	0	
F6.17	Run time limit	0~6000 (days)	1	0	
F6.18	Run time limit	0~23 (hours)	1	0	
F6.19	Reserve				

PID parameter group	F7.00	PID function setting	<b>LED bits:</b> function selection <b>0:</b> PID function off <b>1:</b> PID function on <b>LED ten bits:</b> reserved <b>LED hundreds:</b> reserved <b>LED thousands:</b> reserved	1	0000	
	F7.01	Reserve				
	F7.02	Digital setting	0.0~100.0%	0.1	50.0	
	F7.03	Feedback channel characteristics	<b>0:</b> Positive property <b>1:</b> Inverse characteristic	1	0	
	F7.04	Feedback gain correction	0.100~10.000	0.01	1.000	
	F7.05	PID feedforward action coefficient	0~100	1	0	
	F7.06	Reserve				
	F7.07	Scale factor	0.01~10.00	0.01	1.00	
	F7.08	Integration time	0.00~10.00	0.01	1.00	
	F7.09	Reserve				
	F7.10	PID output reference	<b>0:</b> Upper limit frequency <b>1:</b> Frequency channel set value	1	0	
	F7.11	PID adjustment frequency range	0.0~100.0%	0.1	100.0	
	F7.12	Broken wire detection	0.0~50.0%	0.1	5.0	
	F7.13	Disconnection detection time judgment	0.01~60.00	0.01	5.00	
	F7.14	Static deviation	0.0~10.0%	0.1	0.0	
F7.15 ~ F7.19	Reserve					

## Chapter6 Detailed Description of Functions

### 6.1 Basic operating parameter group

#### **F0.00 Frequency input channel/mode selection Setting range: 0 ~ 5**

It is used to select the setting channel/mode of the inverter's operating frequency.

#### **0: Digital setting**

The set frequency of the inverter is set by the parameter [F0.01].

#### **1: External analog**

The operating frequency is set by the external input voltage signal (0~10V) or current signal (0~20mA). For related characteristics, refer to the description of the parameters [F3.09] and [F3.10].

#### **2: External communication**

Receive the frequency setting command of the upper computer or the host computer through the serial RS485 interface.

#### **3: Panel potentiometer**

The operating frequency is set by the potentiometer on the operation panel.

#### **4: External terminal selection**

Determine the frequency input channel through the external multi-function terminal (the selection of the function terminal is determined by the parameters [F3.01] ~ [F3.04]).



Frequency setting Channel selection 2	Frequency setting Channel selection 1	Frequency setting channel
0	0	Digital setting
0	1	External input signal (0~10V/0~20mA)
1	0	RS485 interface
1	1	Panel potentiometer

**Note:** When the terminal and CM are closed, it is 1.

#### **5: Combination settings**

It is selected by [F0.12] group parameters.

**F0.01 Frequency digital setting**  
**Setting range: 0.00 Hz ~ upper limit frequency**

When the frequency input channel selects the digital setting ([F0.00] = 0), the output frequency of the inverter is determined by this value. When the operation panel is in the normal monitoring mode, you can directly press the   key to modify this parameter.

**F0.02 Parameter write protection Setting range: 0 ~ 20**

This function is used to prevent accidental modification of data.

**5: Only allow to modify function parameter [F0.01] and this parameter**

**9: Only allow to modify this parameter**

Other values: all parameters are allowed to be rewritten.

When it is forbidden to modify the parameters, if you try to modify the data, it will display“- -”.



Some parameters cannot be rewritten during operation. If you try to modify these parameters at this time, "- -" will be displayed. If you want to modify the parameters, please stop the inverter before modifying it.

**F0.03 Upper limit frequency Predetermined area: 5.00~ 400.00Hz**

**F0.04 Lower limit frequency Predetermined area: 0.00 Hz ~ [F0.3]**

This parameter is the lowest frequency lower limit allowed by the inverter. When the frequency is lower than the lower limit frequency, refer to parameter [F0.05] for the mode of action.

**F0.05 Lower limit frequency action mode Predetermined area: 0 ~ 1**

**0: When lower than the lower limit frequency [F0.04], output the lower limit frequency [F0.04]**

**1: Output zero frequency when it is lower than the lower limit frequency [F0.04]**

This parameter can set the hysteresis function to avoid fluctuations near the zero point of the set frequency. When the set frequency is lower than  $f$  ( $f$ =lower limit frequency), the inverter runs at zero frequency. Increase the set frequency. When the set frequency is higher

than the lower limit frequency, the inverter will run at the set frequency. Its function is shown in Figure 6-1:

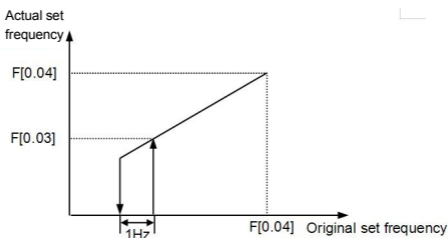



Figure 6-1 Schematic diagram of the lower limit frequency

**F0.06**      **Run command channel and mode selection**  
**Predetermined area: 0000 ~ 1022**

This function parameter is used to select the running command channel of the inverter, and the function of the  key (decimal setting).

### LED units: run command channel selection

#### 0: Keyboard control

The inverter running command is controlled by the  key on the keyboard.

In this mode, the state of the external control terminals X1~X4 (forward running function) can affect the output phase sequence of the inverter. When the external terminals X1~X4 (forward running function) are connected to CM, the inverter outputs the reverse sequence; When X1~X4 are disconnected from CM, the inverter outputs positive phase sequence.

#### 1: External terminal control

The inverter running command is controlled by the on-off status of the multi-function terminals X1~X4 and the CM terminal, and the mode is determined by the LED tens.

#### 2: Serial communication port

The running command of the inverter receives commands from the upper computer or host computer through the serial interface. This mode should also be selected when the machine is set as a slave in the linkage control.

## LED ten digits: operation command mode selection

## 0: Two-line mode 1 (default mode)

Instruction	Shutdown order	Forward command	Reverse instruction
Terminal status			

In the two-wire mode, one input terminal X1~X4 must be selected as the forward control terminal FWD, and the other input terminal X1~X4 is the reverse control terminal REV (refer to the description of parameters [F3.01]~[F3.04])

## 1: Two-line mode 2

Instruction	Shutdown order	Forward command	Reverse instruction
Terminal status			

## 2: Three-line mode

For the three-wire control mode, one input terminal (X1~X4) must be selected as the forward control terminal FWD, one input terminal (X1~X4) is the three-wire operation control terminal SW1, and one input terminal (X1~X4) is the reverse control terminal REV (Refer to the description of parameters [F3.01]~[F3.04]), select any three of the input terminals X1-X4 by parameters [F3.01]~[F3.04].

The switch function description is as follows:

1. SW1(Three-wire operation control terminal) — Inverter stop trigger switch
2. SW2(FWD) — Forward trigger switch
3. SW3(REV) — Reverse trigger switch

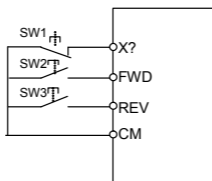

Figure 6-2 Wiring diagram of three-wire control mode

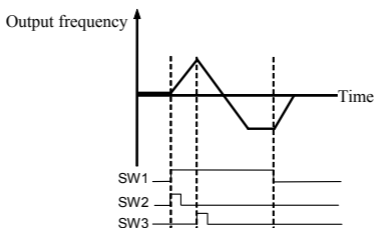

Figure 6-3 Frequency output diagram of three-wire control mode

### 3: Three wire mode 2

The switch functions are described as follows:

1. SW1 (three wire operation control terminal) - inverter operation enable switch
2. SW2 (FWD) - operation stop switch
3. SW3 (Rev) - direction control switch

**Hundreds of LEDs:** reserved

**Thousands of LEDs:** self-start after power-on

- 0:** Power-on self-start prohibition
- 1:** Power-on self-start allowed

**F0.07** *Running direction setting*    *Setting range: 0000 ~ 0011*

**LED ones:** Reverse running direction

- 0:** Invalid
- 1:** Inverted direction is valid

**LED Hundreds:** Reversal prevention

- 0:** Invalid orientation lock
- 1:** Reversal prevention
- 2:** Forward rotation prevention

**F0.08** *Carrier frequency*    *Setting range: 2.0 ~ 8.0 KHz*

This parameter determines the switching frequency of the internal

power module of the inverter.

The carrier frequency mainly affects audio noise and thermal effects during operation. When silent operation is required, the carrier frequency can be slightly increased, but the maximum load that the inverter can carry will decrease, and the interference range of the inverter to the outside world will increase. For long motor cables, the leakage current between the motor cables and between the cable and the ground may also increase. When the ambient temperature is high, the motor load is heavy, or the inverter fails due to the above reasons, the carrier frequency should be appropriately reduced to improve the thermal characteristics of the inverter.

**F0.09 Carrier characteristics Predetermined area, 0000 ~ 0001**

It is used to set some characteristics related to the carrier (digital binary setting), generally without modification.

**LED units: Load-related adjustment**

When this function is valid, when the load current is too large, in order to ensure the safe operation of the inverter, the carrier will be automatically reduced.

**Ten bits of LEDs: fundamental frequency correlation adjustment**

When this function is effective, the carrier wave will be automatically reduced when the frequency converter output frequency is lower than a certain value.

**Hundreds of LEDs: reserved**

**Thousands of LEDs: reserved**

**F0.10 Parameter initialization Predetermined area, 0 ~ 10**

Modify the parameters of the inverter to factory values.

**0: No action**

**1: Standardized initialization** (Restore all parameters to factory settings)

**2: Clear fault record**

**3: Fully initialized**(restore all parameters to factory settings and clear fault records)

**F0.12 Frequency input channel combination Setting range: 0~11**

This parameter is only valid when the frequency input channel

## 40 Detailed Description of Functions

selection combination is set ([F0.00]=5)

The set frequency of the inverter is determined by the linear combination of multiple frequency input channels. The set combination mode is shown in the table below. Through the combination setting, multiple channels can jointly control the frequency output of the inverter.

Set value	Combination method	Set value	Combination settings
0	External voltage setting + panel setting	1	External voltage setting + panel setting + digital setting
2	Communication setting + external voltage setting	3	Communication setting + external voltage setting + panel setting
4	Communication setting-panel setting + digital setting	5	Communication setting-external voltage setting
6	Serial port setting + external voltage setting-panel setting	7	External voltage setting-panel setting + digital setting
8	Panel Setting-Digital Setting	9	UP/DW frequency + external voltage setting
10	UP/DW frequency + panel setting + external voltage setting	11	Digital setting-external voltage setting

**F0.14 acceleration time** Predetermined area; 0.01 ~ 600.00Sec

**F0.15 deceleration time** Predetermined area; 0.01 ~ 600.00Sec

Define the rate at which the output frequency of the inverter changes up and down.

**Acceleration time** The time required for the output frequency to accelerate from 0.00Hz to the upper limit frequency [F0.03].

**Deceleration time** The time required for the output frequency to decelerate from the upper limit frequency [F0.03] to 0.00Hz.

**F0.16 Jog acceleration time** Predetermined area; 0.01 ~600.00Sec

**F0.17 Jog deceleration time** Predetermined area; 0.01 ~600.00Sec

The transition acceleration and deceleration time between the initial running frequency and the jog frequency.

**F0.18 Forward jog frequency** Predetermined area; 0.00Hz ~[F0.03]

**F0.19 Reverse jog frequency** Predetermined area; 0.00Hz~[F0.03]

## 6.2 Basic control parameter group

**F1.00 Start pre-excitation voltage** Predetermined area: 0.0~20.0%

**F1.01 Start pre-excitation time** Predetermined area: 0~10.00 Sec

**F1.02 Start frequency**

Predetermined area: 0.00 ~  $\min([F0.03], 100.00\text{Hz})$

**F1.03 Start frequency duration**

Predetermined area: 0.00 ~ 10.00Sec

This function parameter group is used to define the characteristics related to the startup mode, see Figure 6-4.

**Start frequency:** For systems with large inertia, heavy load, and high starting torque requirements, the starting frequency can effectively overcome starting difficulties. Starting frequency duration (parameter code [F1.03]) refers to the duration of running at the starting frequency, which can be set according to actual needs. When set to 0, the starting frequency is invalid.

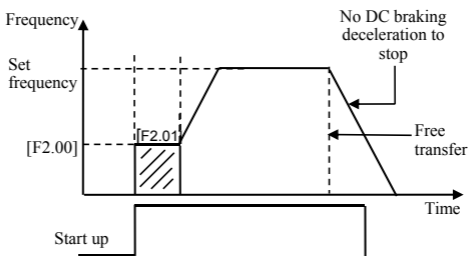

Figure 6-4 Start and stop frequency output curve

**F1.04 Stop mode** Predetermined area: 0 ~ 1

### 0: Decelerate to stop

When stopping, the inverter will gradually reduce its output frequency to zero according to the set deceleration time and then stop.

### 1: Free stop

When stopping, the inverter outputs zero frequency, blocks the

output signal, and the motor runs freely and stops. During a free stop, restart the motor after the motor has completely stopped running, otherwise an over-current or over-voltage fault may occur.

<b>F1.05</b>	<b>Start frequency of DC braking at stop</b> <b>Predetermined area : 0.00 ~ [F0.03]</b>
<b>F1.06</b>	<b>DC braking voltage at stop</b> <b>Predetermined area : 0.0 ~ 20.0%</b>
<b>F1.07</b>	<b>DC braking time at stop</b> <b>Predetermined area : 0 ~20.00 Sec.</b>

This parameter group is used to set the DC braking parameters when stopping.

The initial frequency of DC braking at stop ([F1.05]) is set. When the output frequency of the inverter is lower than this setting parameter when the inverter is stopped, the inverter will block the output, start the DC braking function, and stop the DC braking.

The action time is set by parameter [F1.07]. When the stop DC braking action time is set to 0, the stop DC braking function is invalid.

The stop DC braking current refers to the percentage of the inverter's rated current.

<b>F1.08</b>	<b>Energy consumption braking initial voltage</b> <b>Predetermined area : 340~400V/650~800V</b>
--------------	--

This parameter is valid for the inverter with built-in braking unit and is used to define the action parameters of the built-in braking unit of the inverter. When the internal DC side voltage of the inverter is higher than the initial voltage of dynamic braking, the built-in braking unit will act. If there is an external braking resistor, the internal DC side pumping voltage energy of the inverter will be released through the braking resistor to make the DC voltage drop. When the DC side voltage drops below a certain value ([F1.08]), the built-in braking unit of the inverter is turned off, as shown in Figure 6-5.

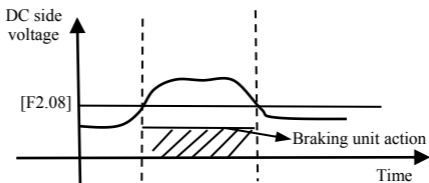

Figure 6-5 Dynamic braking

**F1.09 Dynamic braking action selection**

**0:** Action only when decelerating

**1:** Not limited by deceleration

**F1.11 Undervoltage protection level**

**Predetermined area: 180 ~230V/360 ~460V**

This parameter specifies the allowable lower limit voltage of the DC side when the inverter is working normally. For some occasions where the power grid is low, the undervoltage protection level can be appropriately reduced to ensure the normal operation of the inverter.

**Note: When the grid voltage is too low, the output torque of the motor will decrease.**

For the occasions of constant power load and constant torque load, too low grid voltage will increase the input current of the inverter, thereby reducing the reliability of the inverter operation.

**F1.12 Overvoltage limit action level**

**Predetermined area: 350 ~400V/650 ~800V**

This parameter specifies the threshold for voltage stall protection during motor deceleration. When the pumping voltage on the DC side of the inverter caused by deceleration exceeds the value specified in this parameter, the deceleration time will be automatically extended. As shown in Figure 6-6.

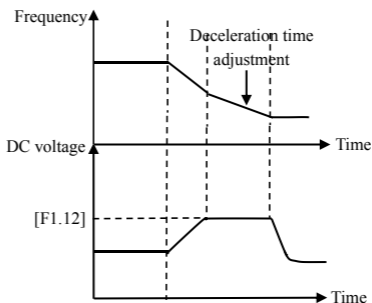

Figure 6-6 Voltage stall protection during deceleration

**F1.13 Accelerating torque level Predetermined area: 120 ~ 220(%)**

This parameter is used to set the allowable output level of the torque current of the inverter during acceleration.

The torque limit level during the acceleration of the inverter is set by [F1.13], which is set as a percentage of the inverter's rated current. If it is set to 150%, it indicates that the output current during acceleration is 150% of the rated current at most.

When the output current of the inverter exceeds the level specified by this parameter, it will automatically extend the acceleration and deceleration time in order to limit the output current within this level, see Figure 6-7. Therefore, for occasions where the acceleration time is required to be short, it is necessary to appropriately increase the acceleration torque level.

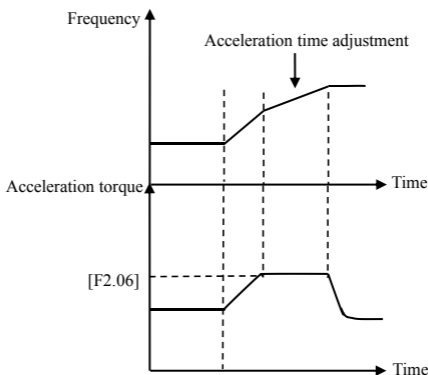

Figure 6-7 Schematic diagram of acceleration torque and braking torque

**F1.14 Current limit level** Predetermined area: 120 ~ 220(%)

This parameter specifies the maximum allowable output current of the inverter, expressed as a percentage of the rated current of the inverter. Regardless of the working state (acceleration, deceleration, steady state operation), when the output current of the inverter exceeds the value specified in this parameter, the inverter will adjust the output frequency to limit the current within the specified range to avoid over-current tripping.

**F1.15 Magnetic flux braking level** Predetermined area: 0~ 100%

This parameter is used to set the magnetic flux braking strength when the frequency converter is stopped. When it is set to 0, the magnetic flux braking is turned off. If the parameter is set too large, it is easy to cause the motor to heat up. It is recommended to use external braking resistance in case of frequent emergency stops.

**F1.16 Motor overload protection factor**  
**Predetermined area: 10 ~ 130 (%)**

This parameter is used to set the sensitivity of the inverter's thermal relay protection to the load motor. When the rated current value of the load motor does not match the rated current of the inverter, the correct thermal protection of the motor can be achieved by setting this value. When it is set to 130%, the inverter closes the motor overload protection function.

The setting value of this parameter can be determined by the following formula:

$$[F1.16] = (\text{Motor rated current} / \text{Inverter rated output current}) \times 100\%$$



When a frequency converter runs in parallel with multiple motors, the thermal relay protection function of the frequency converter will lose its effect. In order to effectively protect the motors, it is recommended to install a thermal protection relay at the inlet end of each motor.

**F1.18 Failure self-recovery times**    **Predetermined area: 0~5**

**F1.19 Fault self-recovery time**    **Predetermined area: 0.00~600.00Sec**

During the operation of the inverter, load fluctuations, grid fluctuations and other accidental factors may cause the inverter to stop due to failure. At this time, in order to ensure the continuity of the system, the inverter is allowed to automatically reset some types of faults and resume operation.

The self-recovery interval time refers to the interval time from the start of the inverter failure to the fault recovery action. If the inverter fails to return to normal within the set number of self-recovery times, the fault signal will be output. After the inverter is successfully restored, it is in the state of stopping and waiting to be started.

### 6.3 Motor parameter group

<b>F2.00</b>	<b>Basic operating frequency</b> <i>Predetermined area: 5.00Hz ~ upper limit frequency</i>
<b>F2.01</b>	<b>Maximum output voltage</b> <i>Predetermined area: 25 ~ 250V/50 ~ 500V</i>

The basic operating frequency is the minimum frequency corresponding to the maximum output voltage of the inverter, generally the rated frequency of the motor.

The maximum output voltage is the corresponding output voltage when the inverter outputs the basic operating frequency, generally the rated voltage of the motor.

These two function parameters need to be set according to the motor parameters. If there are no special circumstances, no modification is required.

**F2.02 Torque boost** *Predetermined area: 0.0 ~ 20.0 (%)*

Used to improve the low-frequency torque characteristics of the inverter. When running in the low frequency range, the output voltage of the inverter is boosted and compensated, as shown in Figure 6-8.

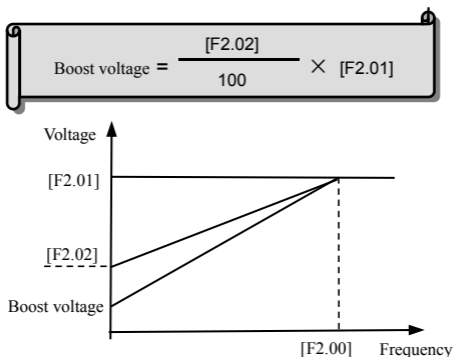

Figure 6-8 Schematic diagram of torque boost

<b>F2.03</b>	<b>V/F frequency 1</b>	<b>Predetermined area: 0.00~[F2.00]</b>
<b>F2.04</b>	<b>V/F voltage 1</b>	<b>Predetermined area: 0~[F2.01]</b>
<b>F2.05</b>	<b>V/F frequency 2</b>	<b>Predetermined area: 0.00~[F2.00]</b>
<b>F2.06</b>	<b>V/F voltage 2</b>	<b>Predetermined area: 0~[F2.01]</b>
<b>F2.07</b>	<b>V/F frequency 3</b>	<b>Predetermined area: 0.00~[F2.00]</b>
<b>F2.08</b>	<b>V/F voltage 3</b>	<b>Predetermined area: 0~[F2.01]</b>

This function parameter group is used to flexibly set the V/F curve required by the user, see Figure 6-9.

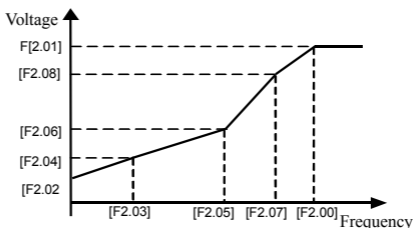

Figure 6-9 V/F custom curve setting

**F2.09 V/F voltage selection** *Predetermined area:0~1*

**0: Standard**                      **1: Enhanced**

**F2.10 Zero frequency torque hold** *Predetermined area:0~1*

**0: The output voltage is 0 at zero frequency**

**1: Set output voltage at zero frequency**

**F2.11 Automatic voltage stabilization** *Predetermined area:0~2*

The automatic voltage stabilization function is to ensure that the voltage of the inverter does not fluctuate with the fluctuation of the input voltage. This function should be turned on when the grid voltage fluctuates greatly and the motor has a relatively stable stator voltage and current.

**0:invalid**                      **1:invalid deceleration**                      **2:efficient**

**F2.12 Number of motor pole pairs** *Predetermined area:1~16*

This parameter is mainly used for the calculation of motor speed.

**F2.16 UP/DW rate** *Predetermined area, 0.10~10.00Hz*

When [F0.00]=5, [F0.12]=9 or 10, and the external input terminal selects UP or DW function, the frequency can be set through the external terminal. This parameter is used to set the given frequency of the external terminal. The rate of rise and fall.

**F2.17** *UP/DW Frequency power down preservation*  
*Predetermined area, 0~1*

**0: Do not save**      **1: Power down preservation**

## 6.4 Digital input and analog parameter group

**F3.00** *Input channel characteristics selection*  
*Predetermined area, 0000~ 1111H*

Used to select external digital input characteristics:

**LED units:** Define the characteristics of the X1 input channel

**0: Positive characteristics**      **1: Inverse characteristics**

**LED ten digits:** Define the characteristics of the X2 input channel

**0: Positive characteristics**      **1: Inverse characteristics**

**Hundreds place of LED:** Define the characteristics of X3 input channel

**0: Positive characteristics**      **1: Inverse characteristics**

**LED Thousands:** Define the characteristics of the X4 input channel

**0: Positive characteristics**      **1: Inverse characteristics**

The positive characteristic is valid when the terminal is closed and invalid when it is disconnected; the inverse characteristic is valid when the terminal is disconnected and invalid when the terminal is closed.

<b>F3.01</b>	<b>Input terminal 1 function selection</b>	<b>Predetermined area; 0 ~ 21</b>
<b>F3.02</b>	<b>Input terminal 2 function selection</b>	<b>Predetermined area; 0 ~ 21</b>
<b>F3.03</b>	<b>Input terminal 3 function selection</b>	<b>Predetermined area; 0 ~ 21</b>
<b>F3.04</b>	<b>Input terminal 4 function selection</b>	<b>Predetermined area; 0 ~ 21</b>

The function definitions of switch input terminals X1 ~ X4 are described as follows:

**0: without**

**1: Multi-speed control 1**

**2: Multi-speed control 2**

**3: Multi-speed control 3**

The combination of the multi-speed control terminal is used to select the output frequency of the multi-speed, and the specific frequency setting of each stage is set by the multi-speed control parameter function code group ([F5.01] ~ [F5.07]).

**4: Forward jog control**

**5: Reverse jog control**

When the run command channel selection external terminal is valid, this parameter defines the input terminal of the external jog signal.

**6: Frequency setting channel selection 1**

**7: Frequency setting channel selection 2**

When the frequency input channel is the external terminal selection (F0.00=4), the frequency setting channel of the inverter is determined by the state of the two terminals. For the corresponding relationship, refer to the relevant description of the [F0.00] parameter.

**8: Free stop control**

Close the terminal corresponding to this parameter, the inverter will block the output.

**9: Three-wire operation control**

When the three-wire mode is selected as the running command terminal combination mode, the external terminal defined by this parameter is the inverter stop trigger switch. For the three-wire control mode, refer to the detailed description of the function code [F0.06].

**10: DC brake control**

When the inverter is stopped, if the terminal defined by this parameter is closed, when the output frequency is lower than the initial frequency of DC braking, the DC braking function will be activated

until the terminal is disconnected. Refer to the description of [F1.05] ~[F1.07] for the relevant parameters of DC braking.

**11: Forward control**

**12: Reverse control**

**13: Fault reset**

When the inverter is in a fault state, closing the terminal set by this parameter can clear the inverter fault.

**14: Reserve**

**15: Emergency stop**

When this parameter setting terminal is valid, the frequency converter will immediately stop according to the emergency stop mode set in [F1.04] thousands.

**16: External fault input**

When the terminal set by this parameter is closed, it indicates that the external equipment has a fault. At this time, for the safety of the equipment, the inverter will block the output and display the external fault signal Fu.16 at the same time.

**17: Disconnection input**

When the terminal set by this parameter is closed, it indicates that the external equipment has a disconnection fault. At this time, for the safety of the equipment, the inverter will block the output and display the external fault signal Fu.17 at the same time.

**18: PLC investment**

When the programmable PLC operation selection condition [F5.00] is valid, the external terminal defined by this parameter can realize the input and removal of PLC operation.

**19: Swing frequency operation input**

When the condition of selecting the swing frequency function is valid ([F4.14]=XXX2). The external terminal defined by this parameter can realize the input and removal of swing frequency operation.

**20: UP**

**21: DW**

The inverter can set the operating frequency through the external terminal and realize the remote frequency setting operation. When the terminal is valid, the set frequency increases or decreases according to the set rate; when the terminal is invalid, the set frequency remains. When both terminals are valid at the same time, the set frequency is maintained. The frequency increases when UP is valid, and decreases

when DW is valid.

<b>F3.09</b>	<b>AI input lower limit voltage</b> <b>Predetermined area : 0.00V ~ [F3.10]</b>
<b>F3.10</b>	<b>AI input upper limit voltage</b> <b>Predetermined area : [F3.09] ~ 10.00 V</b>

[F3.09], [F3.10] define the AI range of the analog input channel, which should be set according to the actual situation of the connected signal.

<b>F3.11</b>	<b>AI input filter time</b>	<b>Predetermined area : 1 ~ 200ms</b>
--------------	-----------------------------	---------------------------------------

The external analog input is filtered to effectively eliminate the interference signal. When the setting is too large, the anti-interference ability is strong but the response speed to the set signal will be delayed.

<b>F3.12</b>	<b>Minimum set frequency</b>	<b>Predetermined area : 0.00Hz ~ [F3.13]</b>
<b>F3.13</b>	<b>Maximum set frequency</b>	<b>Predetermined area : [F3.12] ~ [F0.03]</b>

The corresponding relationship between the analog input AI and set frequency is shown in the figure 6-10.

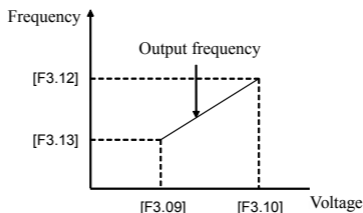

Figure 6-10 Diagram of the corresponding relationship between analog input and set frequency

<b>F3.16</b>	<b>Analog output selection</b>	<b>Predetermined area : 0 ~ 2</b>
--------------	--------------------------------	-----------------------------------

Select the meaning of analog output terminal AO (set in digit decimal system)

**LED units: define the meaning of analog output AO**

**0: Output frequency**

The amplitude of the analog output (AO) is proportional to the output frequency of the inverter. The set upper limit of analog output ([F3.18]) corresponds to the upper limit frequency.

**1: Output current**

The amplitude of the analog output (AO) is proportional to the output current of the inverter. The set upper limit of analog output ([F3.18]) corresponds to twice the rated current of the inverter.

**2: The output voltage**

The amplitude of the analog output (AO) is proportional to the output voltage of the inverter. The set upper limit of analog output ([F3.18]) corresponds to the basic output voltage [F2.01].

**F3.17 AO output lower limit** Predetermined area; 0.00 V ~ [F3.18]

**F3.18 AO output upper limit** Predetermined area; [F3.17] ~ 10.00 V

Define the maximum and minimum values of the analog output AO output signal. As shown in Figure 6-11:

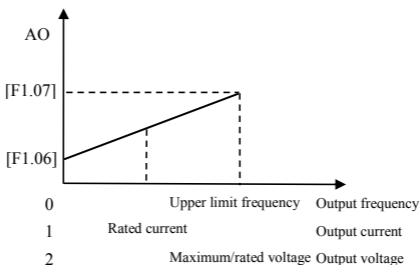

Figure 6-11 Analog output content of analog output

## 6.5 Digital output and swing frequency operation parameter group

<b>F4.00</b>	<b>Output terminal OC function selection</b> <b>Predetermined area: 0 ~ 15</b>
<b>F4.01</b>	<b>Relay output TA/TC function selection</b> <b>Predetermined area: 0 ~ 15</b>

It is used to define the content represented by the open collector output terminal OC and the relay output contact. The internal wiring diagram of the open-collector output terminal is shown in Figure 6-12. When the setting function is valid, the output is low, and when the function is invalid, the output is in a high-impedance state.

Relay contact output: When the set output function is valid, the normally open contact TA-TC is turned on.

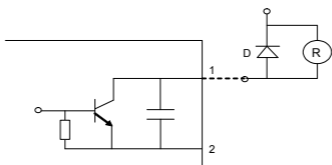

Figure 6-12 Internal wiring of OC output terminal



➤ For When connecting inductive components (such as relay coils), freewheeling diode D must be connected in parallel.

### 0: Inverter is running

When the inverter is running, it outputs an effective signal, and when it is stopped, it outputs an invalid signal.

### 1: Frequency arrives

When the output frequency of the inverter is close to the set frequency to a certain range (the range is determined by parameter [F4.07]), it outputs a valid signal, otherwise it outputs an invalid signal.

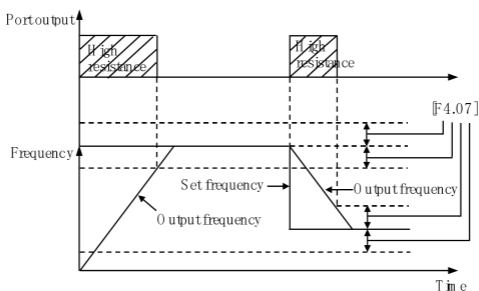

Figure 6-13 Frequency arrival signal

## 2: Frequency level detection (FDT)

When the output frequency of the inverter exceeds the FDT frequency level, the effective signal will be output after the set delay time. When the output frequency of the inverter is lower than the FDT frequency level, the invalid signal will be output after the same delay time.

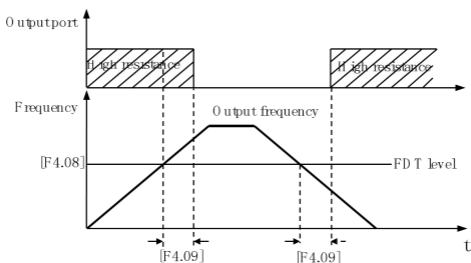

Figure 6-14 Frequency level detection signal

## 3: Overload detection

When the output current of the inverter exceeds the overload alarm level, the effective signal will be output after the set alarm delay time. When the output current of the inverter is lower than the overload

alarm level, after the same delay time, an invalid signal is output.

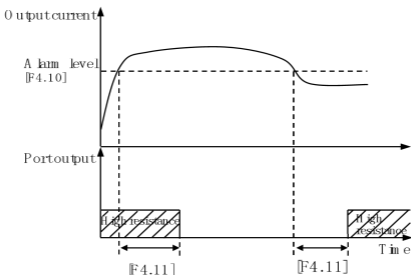

Figure 6-15 Overload alarm

#### 4: Frequency reaches the upper limit

When the output frequency of the inverter reaches the upper limit frequency, this port outputs a valid signal, otherwise it outputs an invalid signal.

#### 5: Frequency reaches the lower limit

When the output frequency of the inverter reaches the lower limit frequency, this port outputs a valid signal, otherwise it outputs an invalid signal.

#### 6: Running at zero speed

When the inverter running command is valid and the output frequency is 0, this port outputs a valid signal; otherwise, it outputs an invalid signal.

#### 7: Undervoltage shutdown

When the voltage on the DC side of the inverter is lower than the specified value, the inverter stops running, and this port outputs a valid signal, otherwise it outputs an invalid signal.

#### 8: Inverter fault

When the inverter stops running due to a fault, it outputs an effective signal; when it is normal, it is in an invalid state.

#### 9: Disconnection fault

When disconnection fault stops running, output valid signal; when normal, it is invalid state

#### 10: PLC cycle completed

#### 11~15: Reserve

#### 13: Reserve

**F4.02 OC and relay output characteristics**  
**Predetermined area: 0000 ~ 0011**

Select the polarity of OC output and relay output by bit. When it is 1, the output polarity is reversed.

**F4.03 Relay action delay** **Predetermined area: 0.00 ~ 30.00Sec**

This parameter is used to set the delay time when the state of the relay output signal changes.

**F4.07 Frequency reaches the detection range**  
**Predetermined area: 0.00 ~ [F0.03]**

It is used to set the frequency defined by the output terminal to reach the detection range. When the output frequency of the inverter is within the positive or negative detection range of the set frequency, the output terminal will output a valid signal, see Figure 6-13.

**F4.08 FDT (frequency level) setting**  
**Predetermined area: 0.00 ~ 20.00 Hz**  
**F4.09 FDT output delay time**  
**Predetermined area: 0.00 ~ 20.00Sec**

This parameter group is used to set the frequency detection level.

When the output frequency is higher than the FDT set value, after the set delay time, the output terminal will output a valid signal.

When the output frequency is lower than the FDT setting value, after the same delay time, the output terminal outputs an invalid signal.

**F4.10 Overload alarm level** **Predetermined area: 20 ~ 200 (%)**  
**F4.11 Overload alarm delay time** **Predetermined area: 0.00~ 600.00Sec**

This parameter group is used to set the overload alarm level and the alarm delay time. When the output current is higher than the set value of [F4.10], after the delay time set by the parameter [F4.11], the output terminal will output a valid signal (Low level), refer to Figure 6-15.

**F4.14 Swing frequency operation setting**  
**Predetermined area: 0000~0012H**

This parameter is used to set the basic characteristics of swing frequency operation. (Minute decimal setting)

**LED units: swing frequency function enable selection**

- 0: Swing frequency function is off**
- 1: Swing frequency function is effective**
- 2: Swing frequency function condition is valid**

When the external swing frequency input terminal is valid (the swing frequency input terminal is selected by the function parameters [F3.01] ~ [F3.04]), it runs in the swing frequency mode.

**LED ten digits: center frequency setting**

- 0: Digital setting, set by [F4.15]**
- 1: Frequency channel selection, given by frequency channel**

**F4.15 Swing frequency center frequency setting**  
**Predetermined area: 0.00~[F0.03]**

The center frequency of swing frequency refers to the center value of the output frequency of the inverter during swing frequency operation.

Refer to Figure 6-17 for the detailed process of swing frequency operation.

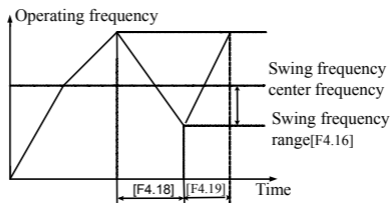

Figure 6-16 Swing frequency operation process

**F4.16 Swing frequency amplitude** **Predetermined area: 0.00~50.0%**

The swing frequency amplitude is the ratio of the swing frequency

amplitude

**Swing frequency amplitude=[F4.16]×upper limit frequency**

**F4.18 Triangle wave fall time** Predetermined area: 0.01~600.00Sec

**F4.19 Triangular wave rise time** Predetermined area: 0.01~600.00Sec

The triangular wave falling time is the running time from the upper limit frequency of the swing frequency to the lower limit frequency of the swing frequency during the swing frequency operation, that is, the deceleration time in the swing frequency operation cycle.

The triangular wave rise time is the running time from the lower limit frequency of the swing frequency to the upper limit frequency of the swing frequency during swing frequency operation, that is, the acceleration time in the swing frequency operation cycle.

## 6.6 Multi-speed section and PLC operating parameter group

**F5.00 Multi-speed operation mode** Predetermined area: 0000~0042H

Basic characteristic setting of multi-speed operation (decimal setting).

**LED units: simple PLC action selection**

**0: Simple PLC is invalid**

**1: Simple PLC effective**

**2: Simple PLC conditions are valid**

When the LED ones place is 1 (PLC is valid), after the inverter is started, the inverter enters the simple PLC running state when the priority of the frequency channel is allowed.

When LED ones place selection 2 (PLC condition is valid), when the external PLC input terminal is valid (PLC input terminal is selected by parameter [F3.01] ~ [F3.04]), the inverter runs in simple PLC mode; external input terminal When it is invalid, the inverter automatically enters the frequency setting mode with lower priority.

**LED ten digits: Simple PLC operation mode selection**

**0: Single loop mode**

The inverter first runs at the set frequency of the first speed, and outputs the frequency step by step according to the set running time. If the set running time of a certain speed is 0, the speed will be skipped,

and the inverter will stop output after running for one cycle. It is necessary to input a valid running command again to start the next cycle.

### **1: Single cycle shutdown mode**

The basic operation mode is the same as mode 0. The difference is that after the inverter runs for a certain speed, it first reduces the output frequency to 0 according to the specified deceleration time, and then outputs the next frequency.

### **2: Keep final value mode**

The basic operation mode is the same as that of mode 0, the inverter will not stop after running a single cycle, and run at a stage speed that is not zero at the last time. The other processes are the same as mode 1.

### **3: Keep set value mode**

The basic operation mode is the same as that of mode 0, the inverter will not stop after running a single cycle, and run at a stage speed that is not zero at the last time. The other processes are the same as mode 1.

### **4: Continuous loop mode**

The basic operation mode is the same as that of mode 0. After one cycle of operation, it starts to cycle from the first speed.

<b>F5.01</b>	<b>Multi-speed frequency 1</b> <i>Predetermined area : 0.00Hz ~ upper limit frequency</i>
<b>F5.02</b>	<b>Multi-speed frequency 2</b> <i>Predetermined area : 0.00Hz ~ upper limit frequency</i>
<b>F5.03</b>	<b>Multi-speed frequency 3</b> <i>Predetermined area : 0.00Hz ~ upper limit frequency</i>
<b>F5.04</b>	<b>Multi-speed frequency 4</b> <i>Predetermined area : 0.00Hz ~ upper limit frequency</i>
<b>F5.05</b>	<b>Multi-speed frequency 5</b> <i>Predetermined area : 0.00Hz ~ upper limit frequency</i>
<b>F5.06</b>	<b>Multi-speed frequency 6</b> <i>Predetermined area : 0.00Hz ~ upper limit frequency</i>
<b>F5.07</b>	<b>Multi-speed frequency 7</b> <i>Predetermined area : 0.00Hz ~ upper limit frequency</i>

This group of parameter function codes is used to set the output frequency of the terminal to control multi-speed operation.



**Hundreds of LEDs: Stage 7 direction selection****0: Positive      1: Reverse****Thousands of LEDs:**

<b>F5.17</b>	<b>PLC running time</b>	<b>Predetermined area: 0 ~ 9999Min</b>
--------------	-------------------------	--

When the programmable multi-speed running function is selected, this parameter is used to set the programmable multi-speed running time. When the time is up, the machine will stop automatically. When the operation is resumed, the stop command should be given first, and then the start command should be given.

When this parameter is set to 0, the timer running stop function is invalid.

**6.7 Communication setting parameter group**

<b>F6.00</b>	<b>Communication settings</b>	<b>Predetermined area: 0000 ~ 0025</b>
--------------	-------------------------------	--

This parameter is used to set communication-related characteristics (decimal setting).

**LED units: baud rate selection**

<b>0: Reserve</b>	<b>1: 1200bps</b>	<b>2: 2400bps</b>
<b>3: 4800bps</b>	<b>4: 9600bps</b>	<b>5: 19200bps</b>

When using serial communication, you must ensure that both parties have the same baud rate.

**LED ten digits: data format selection****0: No verification    1: Even parity    2: Odd parity**

When using serial communication, you must ensure that both parties have the same data format.

**Hundreds of LEDs: reserved****Thousands of LEDs: reserved**

<b>F6.01</b>	<b>Local address</b>	<b>Predetermined area: 0 ~ 127</b>
--------------	----------------------	------------------------------------

Set the local address of the inverter during communication, which is only valid when the local machine is a slave. In the communication process, the machine only sends back response frames to the data frames that match the address of the machine, and receives commands.

0 is the broadcast address. For broadcast data, the slave executes

instructions but does not return corresponding data (see appendix communication protocol).

**F6.02 Local answer delay**      **Predetermined area: 0 ~ 1000 ms**

After the machine correctly receives the information code of the upper computer, it is the waiting time before sending the response data frame.

**F6.03 Linkage settings**      **Predetermined area: 0000 ~ 0011**

When using the linkage function, the master is set to 0011 and the slave is set to 0000 to realize linkage communication.

**F6.04**      **Communication timeout detection time**  
**Predetermined area: 0.1 ~ 20.0 Sec**

When the machine does not receive the correct data signal within the time interval defined by this parameter. Then the machine judges that the communication is malfunctioning. According to the working mode after communication failure set in [F6.05], choose to stop or continue running.

**F6.05**      **Action setting after communication failure**  
**Predetermined area: 0000 ~ 0001**

**LED units: action selection after communication failure**

**0: Downtime**

**1: Maintain current state**

**LED ten digits: reserved**

**Thousands of LEDs: reserved**

**F6.06**      **Communication setting scale factor**  
**Predetermined area: 0.100 ~ 10.000**

This parameter defines the ratio of the output frequency of the master and the slave during linkage control.

This group of parameters of the host inverter does not work. When the linkage synchronization control is realized through the RS485 interface, the running command of the slave machine is completely synchronized with the master machine, and the frequency command of the slave machine is calculated as follows:

**Slave frequency command = Host frequency command × [F6.06]**

**F6.08      *Parameter query and modification permissions***  
***Predetermined area : 0 ~ 60000***

This parameter is a check code value to obtain certain internal parameter query and modification permissions.

**F6.09    *Program Version*    *Predetermined area , 1100 ~ 1199***

Inverter control software version number, read-only parameter.

**F6.10    *Monitoring parameter selection*    *Predetermined area : 0 ~ 20***

This parameter is used to determine the display content of the operation panel in the status monitoring mode.

Monitoring parameter selection is used to determine the display content of the LED.

The physical quantity corresponding to the displayed data can refer to the state monitoring parameter table.

**F6.11      *Linear speed coefficient setting***  
***Predetermined area : 0.001 ~ 60.000***

This parameter sets the display value of the running linear velocity and the set linear velocity, and can also be used to display other physical quantities that are proportional to the output frequency.

Running line speed(d-8)= F6.11 × Output frequency (d-0)  
Set line speed(d-9)= F6.11 × Set frequency (d-7)

## 6.8 PID parameter group

PID control adjusts the output frequency of the inverter by calculating the difference between the feedback value of the controlled system and the target value to adjust the output frequency of the inverter to stabilize the controlled system at the target signal. The schematic diagram is shown in Figure 6-17.

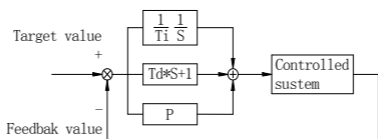

Figure 6-17 PID function diagram

**F7.00 PID feature selection** *Predetermined area: 0000 ~ 0011*

**Ones place: 0:** PID function closed **1:** PID function enable

**Ten place:** reserved

**Hundreds:** reserved

**Thousands:** reserved

**F7.02 PID value given** *Predetermined area: 0.0~100.0%*

**F7.03 Feedback channel feature selection** *Predetermined area: 0~1*

**0:** Positive characteristics

**1:** Inverse characteristics

**F7.04** *Feedback channel correction coefficient*

*Predetermined area: 0.100~10.000*

This parameter can linearly correct the feedback signal.

**F7.05** *PID feedforward action coefficient*

*Predetermined area: 00~100*

**0:** Feed forward function is off

**1~100 :** The feedforward action coefficient can increase the response speed when the system is started.

**F7.06 Reserve****F7.07 Proportional gain** Predetermined area: 0.01~10.00**F7.08 Integration time** Predetermined area: 0.01~10.00 Sec

This parameter group is the built-in PID controller parameter.

**F7.11** **PID frequency adjustment reference**  
 Predetermined area: 0 ~1

**0: Upper limit frequency****1: Frequency channel setting value**

This parameter is set as the upper limit frequency of PID adjustment, which is the percentage of the maximum value of PID output corresponding to the reference reference frequency.

**F7.12** **Lower limit of disconnection detection**  
 Predetermined area: 0.0 ~50.0%

**F7.13** **Disconnection detection delay time**  
 Predetermined area: 0.01 ~60.00Sec

If the feedback value of the system is less than the lower limit of the disconnection detection, it is considered that it may be in a disconnection state and the disconnection is detected. After the delay time, the system is still in the disconnection state, and it is considered that a disconnection fault has occurred.

**F7.14 Static deviation range** Predetermined area: 0 ~10.0%

When the error is within this range, PID will not adjust.

## Chapter 7 Fault Diagnosis And Countermeasures

### 7.1 Protection function and countermeasures

Fault Code	Fault Description	Possible Reasons	Solutions
Fu.01	Over current occurs in inverter acceleration running process	<ol style="list-style-type: none"> <li>1. The acceleration time is too short.</li> <li>2. Start the rotating motordirectly.</li> <li>3. The torque boost is preset as too large.</li> <li>4. The network voltage is too low.</li> </ol>	<ol style="list-style-type: none"> <li>1. Extend acceleration time.</li> <li>2. Restart the motor after stop</li> <li>3. Reduce voltage of torque boost.</li> <li>4. Check the network voltage and reduce power.</li> </ol>
Fu.02	Over current occurs in inverter deceleration running process	The acceleration time is too short.	Increase the acceleration time
Fu.03	Over current occurs in inverter running or stop condition	<ol style="list-style-type: none"> <li>1. Load changes suddenly</li> <li>2. The network voltage is too low.</li> </ol>	<ol style="list-style-type: none"> <li>1. Reduce the load fluctuation.</li> <li>2. Check the power voltage.</li> </ol>
Fu.04	Overvoltage occurs in inverter acceleration running process	<ol style="list-style-type: none"> <li>1. The input voltage is too high.</li> <li>2. Put the power on and off frequently.</li> </ol>	<ol style="list-style-type: none"> <li>1. Check the power.</li> <li>2. Lower the setting of acceleration torque level.</li> </ol>
Fu.05	Overvoltage occurs in inverter deceleration running process	<ol style="list-style-type: none"> <li>1. The acceleration time is too short.</li> <li>2. The input voltage is abnormal.</li> </ol>	<ol style="list-style-type: none"> <li>1. Extend the acceleration time.</li> <li>2. Check the power voltage.</li> <li>3. Install braking resistor or reselect braking resistor.</li> </ol>
Fu.06	Overvoltage occurs in inverter running process	<ol style="list-style-type: none"> <li>1. The power voltage is abnormal.</li> <li>2. There is energy feedback load.</li> </ol>	<ol style="list-style-type: none"> <li>1. Check the power voltage.</li> <li>2. Install the braking unit and braking resistor or reselect braking resistor.</li> </ol>
Fu.07	Overvoltage occurs in inverter stop condition	The power voltage is abnormal.	Check the power voltage.
Fu.08	Under-voltage occurs in inverter running process	<ol style="list-style-type: none"> <li>1. The power voltage is abnormal.</li> <li>2. There is starting operation of heavy load in network.</li> </ol>	<ol style="list-style-type: none"> <li>1. Check the power voltage.</li> <li>2. Supply power separately.</li> </ol>
Fu.09 ~ Fu.10	Reserve		
Fu.11	Electromagnetic interference	Jamming drive signal	<ol style="list-style-type: none"> <li>1. Check whether the wiring is reasonable.</li> <li>2. The strong and weak lines are separated.</li> </ol>

## 68 Fault Diagnosis And Countermeasures

<b>Fault Code</b>	<b>Fault Description</b>	<b>Possible Reasons</b>	<b>Solutions</b>
Fu.12	Inverter overload	<ol style="list-style-type: none"> <li>1. The load is too large.</li> <li>2. The acceleration time is too short.</li> <li>3. The torque boost is too high.</li> <li>4. The network voltage is too low.</li> </ol>	<ol style="list-style-type: none"> <li>1. Reduce load or change a larger capacity inverter.</li> <li>2. Extend the acceleration time.</li> <li>3. Reduce the voltage of torque boost.</li> <li>4. Check the network voltage.</li> </ol>
Fu.13	Motor overload	<ol style="list-style-type: none"> <li>1. The load is too large.</li> <li>2. The acceleration time is too short.</li> <li>3. The protection factor Setting is too small.</li> <li>4. The torque boost is too high.</li> </ol>	<ol style="list-style-type: none"> <li>1. Reduce load.</li> <li>2. Extend the acceleration time.</li> <li>3. Increase the overload protection factor of motor.</li> <li>4. Reduce torque boost.</li> </ol>
Fu.14	Inverter overheat	<ol style="list-style-type: none"> <li>1. Air duct obstruction</li> <li>2. The environment temperature is too high.</li> <li>3. The fan is damaged.</li> </ol>	<ol style="list-style-type: none"> <li>1. Clean air duct or improve ventilation condition.</li> <li>2. Improve the ventilation condition and reduce the carrier frequency.</li> <li>3. Change fan.</li> </ol>
Fu.15	Reserve		
Fu.16	External equipment fault	The exterior fault input terminal is ineffective.	<ol style="list-style-type: none"> <li>1. Check the exterior equipment.</li> <li>2. Disconnect the external fault input terminal.</li> </ol>
Fu.17	PID feedback off-line	<ol style="list-style-type: none"> <li>1. The feedback signal is lost.</li> <li>2. The setting of off-line detection threshold value is not appropriate.</li> </ol>	<ol style="list-style-type: none"> <li>1. Check line.</li> <li>2. Reduce threshold value of off-line detection.</li> </ol>
Fu.18 ~ Fu.19	Reserve		
Fu.20	Current detection error	The current detection devices or circuit is damaged.	<ol style="list-style-type: none"> <li>1. Check socket line.</li> <li>2. Ask for manufacturers' assistance.</li> </ol>
Fu.21 ~ Fu.39	Reserve		
Fu.40	Internal data EEPROM error	The read-write errors of control parameters.	Ask for manufacturers' assistance.

## 7.2 Fault record query

The series of inverters recorded the recent fault code occurred in the last four times and the inverter output parameters of the last fault; query of these information will contribute to find fault causes.

Monitoring project	content	Monitoring project	content
d-20	The first fault record	d-26	The output voltage of the last fault recently
d-21	The second fault record	d-27	The direct voltage of the last fault recently
d-22	The third fault record	d-28	The module temperature of the last fault recently
d-23	The fourth fault record	d-29	The set frequency of the last fault recently
d-24	The output frequency of the last fault recently	d-30	The running status of the last fault recently
d-25	The output current of the last fault recently		

The fault information and condition monitoring parameters are stored in a unified manner; please refer to the keyboard operation method to query information.

## 7.3 Fault reset



- The fault causes must be identified and removed completely prior to reset, otherwise it may cause permanent damage to the inverter.
- If the inverter can't be reset or fault occurs after reset, it's necessary to find out causes, otherwise continuous reset will damage the inverter.
- The protection actions of overload and overheat should be delayed for 5 minutes when reset.

To recover to the normal operation when the inverter fault occurs, it's optional to choose any of the following operations.

Method I: Press  key when displaying fault code.

Method II: Disconnect after closure of external multi-function terminals X1~X4 (fault reset) and CM.

Method III: Send the fault reset command via RS485 interface.

Method IV: Cut off power supply.

## Appendix I: MODBUS Protocol Specification

### 1. Communication setting

The protocol is MODBUS RTU.

### 2. Communication function

Complete communication between upper machine and inverter, including sending operation command to inverter, setting running frequency, rewriting function code parameter, reading running status of inverter, monitoring parameter, fault message and function code parameter.

### 3. Protocol format

MODBUS RTU format

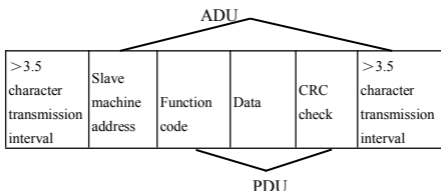

#### 3.1 Interpretation of protocol format

##### 1. Slave address

0 is broadcast address and the slave address can be set as 1-127.

##### 2. PDU part

(1) **Function code 03:** Read functional parameters, running status, monitoring parameter and fault message of multiple inverters, and 6 inverter parameters with continuous address at most in one time.

Sent by main machine:

PDU PART	03	Register initial address		Number of registers	
		High	Low	High	Low
Data length(Byte)	1	1	1	1	1

Slave machine response:

PDU PART	03	Number of reading bytes (2*Number of registers)	Reading content
Data length(Byte)	1	1	2*Number of registers

**(2) Function code 06:** Rewrite operation command, running frequency and functional parameter of single inverter.

Sent by main machine:

PDU PART	06	Register initial address		Register data	
		High	Low	High	Low
Data length(Byte)	1	1	1	1	1

Slave machine response:

PDU PART	06	Register initial address		Register data	
		High	Low	High	Low
Data length(Byte)	1	1	1	1	1

**(3) Function code 10:** Rewrite operation command, running frequency and functional parameter of multiple inverters.

Sent by main machine:

PDU PART	10	Register initial address		Number of registers		Content byte count	Register content
		High	Low	High	Low		
Data length(Byte)	1	1	1	1	1	1	2*Number of registers

Slave machine response:

PDU PART	10	Register initial address		Number of registers	
		High	Low	High	Low
Data length(Byte)	1	1	1	1	1

**Notice:** the inverter starts to store data from the register with lowest address to that with the highest address, and 6 function codes can be saved at most in one time; in case of identifying some error, the slave machine will make objection response.

Objection response:

PDU PART	0x80 + Function code	Objection code
Data length(Byte)	1	1

Objection code indicates error category:

Objection code	Corresponding error
01	Illegal function code
02	Illegal data address
03	Overhanging dataD
04	Invalid operation of slave machine
20	Too much read-write parameters
21	Reserve read-write, implicit parameter
22	Slave machine running forbids modifying data
23	Data modification is protected by password
24	Failure in read-write parameter

CRC CHECK:

CRC CHECK	CRC Low	CRC High
Data length(Byte)	1	1

CRC CHECK function is shown as below:

```
unsigned int crc_chk_value(unsigned char *data_value, unsigned
char length)
```

```
{
    unsigned int crc_value=0xFFFF;
    int i;
    while(length--)
        { crc_value^=*data_value++;
          for(i=0;i<8;i++)
            { if(crc_value&0x0001)
              crc_value=( crc_value>>1)^0xA001;
            else
              crc_value= crc_value>>1;
            }
        }
    return(crc_value);
}
```

### 3. Definition of communication parameter address

Distribution of inverter parameter address

Register implication	Register address space
Functional parameter <sup>(1)</sup>	High is the number of function code group, while low is mark number of function code, e.g. F1.11, the register address is F10B.
Monitoring parameter	High is 0xD0 and low is monitoring mark number, e.g. d-12, the register address is D00C
Operation command <sup>(2)</sup>	0x1001
Frequency setting	0x1002
Inverter status <sup>(3)</sup>	0x2000
Fault message <sup>(4)</sup>	0x2001

**Note:**

(1) The frequent writing of function code parameters in the EEPROM will reduce its service life. Some parameters in the communication mode don't need to store, but to modify the RAM value. When writing the functional parameter of RAM, just change "F" to "0" in the high address of the register, e.g. when writing the RAM value of F1.11, its register address should be 010 B, but the expression method of the register address cannot be used to read the functional parameters of the frequency inverter.

(2) Operation command corresponding to operation command code:

Operation command code	Operation command
0x0000	Invalid command
0x0001	FWD running start
0x0002	REV running start
0x0003	Stop
0x0004	FWD inching of slave machine
0x0005	REV inching of slave machine
0x0006	Inching running stops
0x0020	Fault reset of slave machine

## (3) Inverter status:

Inverter status code	Indication
0x0000	The direct voltage of slave machine is not ready
0x0001	In FWD running of slave machine
0x0002	In REV running of slave machine
0x0003	Slave machine stops
0x0004	In FWD inching running of slave machine
0x0005	In REV inching running of slave machine
0x0011	In FWD acceleration
0x0012	In REV acceleration
0x0013	Instant stop and restart
0x0014	FWD deceleration
0x0015	REV deceleration
0x0016	Slave machine stays in DC braking condition
0x0020	Slave machine stays in fault condition

(4)The high fault message code is 0, while low is corresponding to the rear mark number of inverter fault code-Fu., e.g. if the fault message code is 0x000C, it represents that inverter fault code is Fu.12.

## 1.2 Example

(1). Start 1 # inverter in FWD running condition

Main machine request:

Slave machine address	Function code	Register initial address		Register data		CRC CHECK	
		High	Low	High	Low	Low	High
01	06	10	01	00	01	1D	0A

Slave machine response: inverter in FWD running condition responds the same data with main machine request.

(2). Set inverter running frequency as 50.0Hz

Main machine request:

Slave machine address	Function code	Register initial address		Register data		CRC CHECK	
		High	Low	High	Low	Low	High
01	06	10	02	13	88	21	9C

Slave machine response: inverter in 50.0Hz running condition responds the same data with main machine request.

(3). Read current running frequency, output current, inverter response frequency 50.0Hz and output current 1.1A of inverter.

Main machine request:

Slave machine address	Function code	Register initial address		Number of registers		CRC CHECK	
		High	Low	High	Low	Low	High
01	03	D0	00	00	02	FC	CB

Slave machine response:

Slave machine address	Function code	Number of reading bytes	1st register data		2nd register data		CRC CHECK	
			High	Low	High	Low	Low	High
01	03	04	13	88	00	0B	3F	5A

(4). Start 1 # inverter in FWD running condition and set inverter running Frequency as 40. 0Hz.

Main machine request:

Slave machine address	Function code	Register initial address		Number of registers		Number of content bytes	1st register data		2nd register data		CRC CHECK	
		High	Low	High	Low		High	Low	High	Low	High	
01	10	10	01	00	02	04	00	01	0F	A0	AB	EB

Slave machine response:

Slave machine address	Function code	Register initial address		Number of registers		CRC CHECK	
		High	Low	High	Low	Low	High
01	10	10	01	00	02	14	C8

## Appendix II: Brake resistor selection

In running process of inverter, in case that controlled motor speed falls too fast or motor load shakes too fast, the electromotive force will charge inverter internal capacitance through inverter in reverse direction, therefore, voltage at two ends of power module will be boosted to damage inverter possibly. The inverter internal control will be suppressed based on loading condition; in case of brake performance failing to meet customer requirements, it's necessary to connect with external brake resistor to realize immediate release of energy. The external brake resistor belongs to energy-consumption brake mode, which will consume all energy on power brake resistor. Therefore, selection of power and resistance value of brake resistor must be reasonable. The following content refers to introducing brake resistor power and resistance value recommended to be employed for SAM inverter. Based on loading condition, user can modify value properly in line with the range specified by SAM inverter.

Inverter model	Applicable motor (KW)	Brake resistor power (KW)	Brake resistance value ( $\Omega$ )	Braking torque (%)
SL100-2S0004(B)Q	0.4	0.1	150	100
SL100-2S0007(B)Q	0.75	0.1	100	100
SL100-2S0015(B)Q	1.5	0.2	70	100
SL100-2S0022(B)Q	2.2	0.2	50	100
SL100-2S0030(B)Q	3.0	0.4	40	100
SL100-2S0040(B)Q	4.0	0.4	35	100
SL100-4T0007(B)Q	0.75	0.1	400	100
SL100-4T0015(B)Q	1.5	0.2	300	100
SL100-4T0022(B)Q	2.2	0.4	200	100
SL100-4T0040(B)Q	4.0	0.5	125	100
SL100-4T0055(B)Q	5.5	0.8	100	100
SL100-4T0075(B)Q	7.5	1.0	85	100

The above configuration is to realize 100% braking torque, it's necessary to select value in actual use based on braking condition. In case of weak braking, please reduce brake resistance properly and increase brake resistance power class in proportion.



The brake resistance power is the estimated value in working condition of brake resistance interval; when continuous working time of brake resistance is longer (more than 5s), it's necessary to properly increase power class of brake resistance under the condition of same resistance value.